

Air Force Institute of Technology

AFIT Scholar

Theses and Dissertations

Student Graduate Works

3-2001

Technology Selection for Enhancing F-16 Capability: An Analysis Using Value Focused Thinking

Cihangir Yay

Follow this and additional works at: <https://scholar.afit.edu/etd>



Part of the [Operational Research Commons](#)

Recommended Citation

Yay, Cihangir, "Technology Selection for Enhancing F-16 Capability: An Analysis Using Value Focused Thinking" (2001). *Theses and Dissertations*. 4727.

<https://scholar.afit.edu/etd/4727>

This Thesis is brought to you for free and open access by the Student Graduate Works at AFIT Scholar. It has been accepted for inclusion in Theses and Dissertations by an authorized administrator of AFIT Scholar. For more information, please contact richard.mansfield@afit.edu.



**TECHNOLOGY SELECTION FOR ENHANCING
F-16 CAPABILITY:**

**AN ANALYSIS USING VALUE FOCUSED
THINKING**

THESIS

Cihangir Yay, 1ST Lieutenant. TUAF

AFIT/GOR/ENS/01M-19

**DEPARTMENT OF THE AIR FORCE
AIR UNIVERSITY**

AIR FORCE INSTITUTE OF TECHNOLOGY

Wright-Patterson Air Force Base, Ohio

APPROVED FOR PUBLIC RELEASE; DISTRIBUTION UNLIMITED.

20010619 028

The views expressed in this thesis are those of the author and do not reflect the official policy or position of the United States Air Force, Department of Defense, or the U.S. Government.

AFIT/GOR/ENS/01M-19

**TECHNOLOGY SELECTION FOR ENHANCING F-16 CAPABILITY:
AN ANALYSIS USING VALUE FOCUSED THINKING**

THESIS

Presented to the Faculty
Department of Operational Sciences
Graduate School of Engineering and Management
Air Force Institute of Technology
Air University
Air Education and Training Command
In Partial Fulfillment of the Requirements for the
Degree of Master of Science in Operations Research

Cihangir Yay, B.S.
1st Lieutenant, TAAF

March 2001

APPROVED FOR PUBLIC RELEASE; DISTRIBUTION UNLIMITED.

**TECHNOLOGY SELECTION FOR ENHANCING F-16 CAPABILITY:
AN ANALYSIS USING VALUE FOCUSED THINKING**

**Cihangir Yay, B.S.
1st Lieutenant, TAAF**

Approved:



Stephen P. Chambal (Co-Chairman)

02 MAR 01
Date

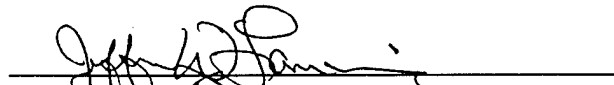

Jeffrey W. Lanning (Co-Chairman)

02 Mar 01
Date

Acknowledgments

I would like to express my sincere gratitude to my faculty advisors, Capt. Stephen Chambal and Maj. Jeffrey Lanning for guiding me through for this project. I would have never finished without their help. Their patience and experiences are also greatly appreciated.

This project was a team effort in many ways. Thanks also go out to our great team members, Mr. Hanke, Maj. Kricker, and Capt. Bullerman. who spent a great deal of time in building the value model used throughout this project.

Most importantly, I want to thank my fiancée and my family for the endless emotional support that they provided. This support showed me the way during many sleepless nights of this project.

Cihangir Yay

Table of Contents

	Page
Acknowledgments	iv
List of Figures	viii
List of Tables.....	x
Abstract	xii
1. Introduction	1
1.1 Background	1
1.2 Problem Statement	3
1.3 Objective and Scope of the Research	3
1.4 Summary and Organization.....	4
2. Literature Review	6
2.1 Introduction	6
2.2 F-16 Safety Program	6
2.2.1 Hazard Control Decision Process.....	7
2.2.2 Risk Assessment.....	9
2.3 Combat Capability.....	11
2.4 Operations Cost	12
2.5 Decision Analysis.....	12
2.6 R&D Selection Models	16
2.6.1 Analytical Hierarchy Process	17
2.6.2 Value Focused Thinking	19
2.6.2.1 Examples of Value Focused Thinking	20
2.6.2.2 Value Hierarchy Development Methods.....	22
2.6.2.3 Developing Evaluation Measures.....	26
2.6.2.4 Single Dimensional Value Functions	27
2.6.2.5 Assessing Weights.....	28
2.6.2.6 Finding Alternatives and Attribute Scoring	31
2.6.2.7 Ranking of Results	31
2.6.2.8 Sensitivity Analysis.....	32
2.7 Resource Allocation	32
2.8 Summary	34
3. Methodology	35
3.1 Introduction	35
3.2 Analysis Process and Framework.....	36

	Page
3.3	Method for the Value Hierarchy38
3.4	Building the Value Hierarchy.....39
3.4.1	Introduction39
3.4.2	Building the Model.....39
3.5	Model Definitions42
3.5.1	Combat Capability.....43
3.5.1.1	Aircraft Availability45
3.5.1.2	Combat Score46
3.5.2	Safety Impact.....47
3.5.2.1	Total Class A Mishap Rate Change50
3.5.2.2	Installation Schedule54
3.5.3	Operational Costs57
3.5.3.1	RTOC Costs58
3.5.3.2	Non-RTOC Costs61
3.6	Single Dimensional Value Functions62
3.6.1	UER Drivers.....62
3.6.2	Number of Class A Accidents (Initial-Threshold/Final)64
3.6.3	Number of Class A Accidents (Mitigated-Threshold/Final).....65
3.6.4	Weighted Annual Percentages.....66
3.6.5	Delta O&S Parts67
3.6.6	Delta O&S Labor68
3.6.7	Maintenance Man Hours69
3.7	Using Additive Value Function.....70
3.8	Determining the Weights.....71
3.9	Modeling Assumptions.....75
3.10	Methodology Summary76
4.	Results and Analysis77
4.1	Introduction77
4.2	Model Application and Ranking the Alternatives.....79
4.2.1	The F-16 Capability Enhancement Model Ranking for Mission Type and War Capabilities79
4.2.2	The F-16 Capability Enhancement Model Ranking for Fleet Size91
4.2.3	The F-16 Capability Enhancement Model Ranking for Pratt Whitney Engines.....94
4.3	Cost of Enhancing the F-16 Capabilities.....95
4.4	Optimizing the Portfolio.....103
4.5	What-If Analysis106
4.6	Sensitivity Analysis.....111
4.7	Summary112
5.	Conclusions114
5.1	Introduction114

	Page
5.2 Conclusions	115
5.3 Recommendations for Future Research.....	116
5.4 Lessons Learned.....	118
5.5 Summary	120
Appendix A. F-16 Engines.....	121
Appendix B. Metamorphoses of the Model	124
Appendix C. Sensitivity Analysis.....	128
Appendix D. Modifications' Data	130
Appendix E. Macros Created for Value Functions.....	166
Bibliography	169

List of Figures

	Page
2.1 Hazard Control Decision Process.....	8
2.2 The Decision Process	15
2.3 Value Hierarchy	24
2.4 Piecewise Linear and Exponential Single Dimensional Value Function Example	28
2.5 Assessing the Weights Example.....	29
2.6 Assessing the Weights Example: Mathematical Procedure	30
3.1 Study Framework	37
3.2 The Final Model and Modified VFT Approach	40
3.3 Modified VFT Approach Example.....	41
3.4 Objectives of the Model	43
3.5 Combat Capability.....	45
3.6 Safety Impact.....	50
3.7 Risk.....	51
3.8 A Comparison Example	53
3.9 Operations Cost	59
3.10 Modernization vs. Costs	60
3.11 UER Drivers	64
3.12 Number of Class A Accidents (Initial-Threshold/Final)	65
3.13 Number of Class A Accidents (Mitigated-Threshold/Final)	66
3.14 Weighted Annual Percentages.....	67
3.15 Finding the Ratios for Hardware	68
3.16 Delta O&S Parts	68

	Page
3.17 Delta O&S Labor.....	69
3.18 Maintenance Man Hours	70
3.19 Local and Global Weights.....	72
3.20 Global Weights of the F-16 Capability Enhancement Model	73
3.21 Global Weights of the Evaluation Measures.....	74
4.1 The F-16 Capability Model Parts	77
4.2 Fundamental Objective’s Contributions.....	82
4.3 Ranking for Combat Capability	84
4.4 Ranking for Safety.....	86
4.5 Ranking for Operations Cost.....	88
4.6 Evaluation Measures’ Contributions	90
4.7 Plot of Cumulative Cost versus Cumulative Benefit for Mission Type and War Capabilities	99
4.8 Plot of Cumulative Cost versus Cumulative Benefit for Fleet Size	100
4.9 Plot of Cumulative Cost versus Cumulative Benefit for PW Engines	102
4.10 Effective Sets Comparisons.....	105
4.11 Sensitivity of Weights for UER Drivers.....	112

List of Tables

	Page
2.1 Hazard Severity Categories	9
2.2 Hazard Probability Categories and Rates	10
2.3 Hazard Risk Assessment Matrix with Acceptability Criteria.....	11
2.4 NASA's Objectives	20
2.5 Ranking of NASA missions in terms of their consequences for each NASA objective.....	21
3.1 An Example for Installation Schedule.....	48
3.2 Hypothetical Best and Worst Cases	54
3.3 An Installation Schedule Example: Aircraft Numbers	55
3.4 Factoring the Years	55
3.5 Normalization Values.....	56
3.6 The Results of Installation Schedule Example.....	56
3.7 UER Drivers.....	63
4.1 Decision Weights	79
4.2 Ranking for Mission Type and War Capabilities	80
4.3 An example for Hypothetical Best and Worst Cases	81
4.4 Normalization for Aircraft Number.....	92
4.5 Decision Weights for Fleet Size.....	92
4.6 Ranking for Fleet Size.....	93
4.7 Ranking for PW Engines.....	94
4.8 Benefit/Cost Ratio Ranking for Mission Type and War Capabilities	96
4.9 Benefit/Cost Ratio Ranking for Fleet Size	96
4.10 Benefit/Cost Ratio Ranking for PW Engines	97

	Page
4.11 Greedy Algorithm Results for Mission Type and War Capabilities	98
4.12 Greedy Algorithm Results for Fleet Size	100
4.13 Greedy Algorithm Results for PW Engines	101
4.14 Coded Modifications	104
4.15 Optimization for Fleet Size	105
4.16 What-If Case 1.....	107
4.17 Ranking for Fleet Size (What-If Case 1).....	108
4.18 What-If Case 2.....	109
4.19 Ranking for Fleet Size (What-If Case 2).....	110

Abstract

This study, with support of the Aeronautical Systems Center, builds a scientific decision support system intended for Air Combat Command. Past decision-making techniques are discussed and their limitations are explained. Two multiattribute decision-making techniques, analytical hierarch process and value focused thinking, are studied. Due to limitations of analytical hierarchy process, value focused thinking is accepted as the best fit for our problem. A value hierarchy model is developed using value focused thinking for selecting the most beneficiary F-16 engine modifications depending on anticipated Air Combat Command values. Ten modifications are ranked using value model to validate the process. Cost is involved in the rankings to show the benefit per dollar invested. Optimization techniques are used to form various effective modification sets due to changing budget constraints. Sensitivity analyses show that the model is weight sensitive. This study proves that multiattribute decision-making techniques and particularly value focused thinking approach can be used to create a scientific decision support system for Air Combat Command.

TECHNOLOGY SELECTION FOR ENHANCING F-16 CAPABILITY: AN ANALYSIS USING VALUE FOCUSED THINKING

Chapter 1: Introduction

1.1 Background

In today's technology-driven world, organizations that perform research and development (R&D) are forced to make tough and risky decisions about their financial investments. Decision-makers may face unfamiliar technologies when making decisions. If the decision-maker does not understand the technology, the company may face budget cuts and lose market share to the competition. Decision-makers need to show that their decisions have an additive value to the organization's existing position. Bad decisions might result in losing money for short term and can lead to losing capabilities of the company in the long term. The goal is to choose technologies to benefit their competitive advantage.

The military organizations throughout the world are spending a vast amount of money for R&D projects. Military decision-makers must understand the value for a particular R&D project since poor R&D project selection can lead to losses of lives and

losses of strategic objectives. Modernization of equipment is a good example of R&D project selection in military. New technologies have to be integrated into existing equipment to keep their benefit for the armed forces. However, selecting which technologies is not an easy process. Multiple objectives must be considered (costs, safety, etc.). This research builds a mathematical model to support the decision process of selecting F-16 engine modifications.

The goal of decision analysis is to help individuals make good decisions (Ragsdale, 2001: 714). Unforeseeable circumstances and complex systems obscure decisions and may result in poor outcomes. The better the decision-maker understands the system, the better the decision will be for selecting technologies. The decision-making process requires decomposing the problem and creating a framework for achieving the objectives of the company or organization.

The scientific method provides this framework. Often, individuals rely on intuitive methods to solve the problems of daily life by comparing between alternatives. However, R&D selection projects include multiple competing objectives and tradeoffs are required between these objectives. More than an intuitive method, we need a philosophy, a systematic way to approach decision-making process. A key to good decision-making is to provide a structured method for incorporating the information, opinions, and preferences of the various relevant people into the decision-making process (Kirkwood, 1997:1).

Technology selection models help the decision-maker choose between evolving technologies. Some mathematical programming approaches have been used for technology selection models in the past (Weingartner, 1963; Lorie & Savage, 1955).

Linear programming is a good example of a mathematical approach, which is used for portfolio selection. Such approaches, however, do not capture the different aspects of the competing alternatives (Baker and Freeland, 1975). New approaches have been developed to assist in decision-making process over the last decades.

New analysis methods concentrate on the decision-making process for multiple objectives, requiring tradeoffs among competing objectives. These methods can be applied to decision-making processes for new technologies. This research examines and implements strategic decision-making tools for multiple objectives.

1.2 Problem Statement

The purpose of this thesis is to develop a mathematical model to pick a set of best modifications for F-16 capability enhancement. Values (what is important to decision-makers about choosing the engine modifications) are used in the model to quantify how well various modifications enhance F-16 capability. The model will provide insights to the F-16 System Program Office (SPO) in selecting sets of modifications for future integration into the aircraft. The main considerations for the modifications are combat capability, safety, and operational costs.

1.3 Objective and Scope of the Research

The main objective is to use value focused thinking (VFT) to develop an overall modification selection model with the SPO and Aeronautical Systems Center (ASC). The model reflects the anticipated needs of Air Combat Command (ACC). The goal of

the model is to rank modification alternatives based on combat capability, safety enhancements and operations costs.

1.4 Summary and Organization

Chapter 2 documents literature reviewed for the purpose of this study. It explains the F-16 safety process, F-16 combat capability highlights, and cost aspects for the model. Decision analysis and R&D selection models are also introduced with some selected applications. An in-depth discussion is provided on the value focused thinking approach. Finally, resource allocation models are highlighted.

Chapter 3 applies the results of Chapter 2 to our specific problem. First, how to choose an appropriate model for R&D portfolio selection is discussed. Next, a detailed discussion is provided on developing a value hierarchy model for the F-16 capability enhancement model. In the process, in-depth insights on VFT and its procedures are explained. Single dimensional value functions are formed depending on the preferences of the decision-maker. Weights of the model are introduced using examples. Assumptions of the model are explained to complete the chapter.

Chapter 4 shows the results of an illustrative analysis on a small subset of modifications by choosing the best portfolio. Acquisition cost for an engine and total cost for the modifications are studied in a benefit/cost ratio analysis to provide better insights about the value of the modifications. Integer programming is used for selecting effective modification sets using budget constraint.

Chapter 5 concludes the study and provides final insights, recommendations and areas for future research. Specifically we focus on engine modifications. This chapter also includes a lessons learned or process tips section to help future researchers. The appendices provide more detailed information on the data gathering and model building process.

Chapter 2:Literature Review

Nothing is more difficult, and therefore more precious, than to be able to decide.

NAPOLEON,
Maxims, 1804

2.1 Introduction

This chapter discusses the F-16 program and the decision-making concepts used in this study. Safety, combat capability and operations costs are explained to introduce the F-16 model terminology. Decision analysis is discussed and an in-depth discussion is provided on the VFT approach to decision-making. Analytical hierarchy process (AHP) is also introduced as an alternative decision making process. Some examples from the literature that discuss these methods as applied to decision analysis in recent history are presented. Characteristics and limitations of resource allocation and R&D models are examined to complete the chapter.

2.2 F-16 Safety Program

The F-16 system safety program plan (SSPP) is a working document that reflects the policies and procedures that identify and eliminate or control identified hazards for the common configuration implementation program (CCIP) and other F-16 acquisition reform programs. The SSPP is structured in accordance with a military safety document, MIL-STD-882C, to provide guidance for accomplishing the F-16 safety program by the

assigned system safety engineers. The safety team monitors the performance and progress of the program and modification changes.

2.2.1 Hazard Control Decision Process

Figure 2.1 illustrates the hazard control decision process. The key point to note from this decision process flow chart is that the primary (and majority of) decisions are normally made informally at the working level between system safety engineers and design engineers. When agreement cannot be reached at the working level, system safety issues are formally documented and elevated for a management decision. The hazard control decision process is terminated when:

- The hazard is eliminated or adequately controlled by changing the design , or
- The risk is accepted, documented and reported to the F-16 SPO and Ogden safety offices.

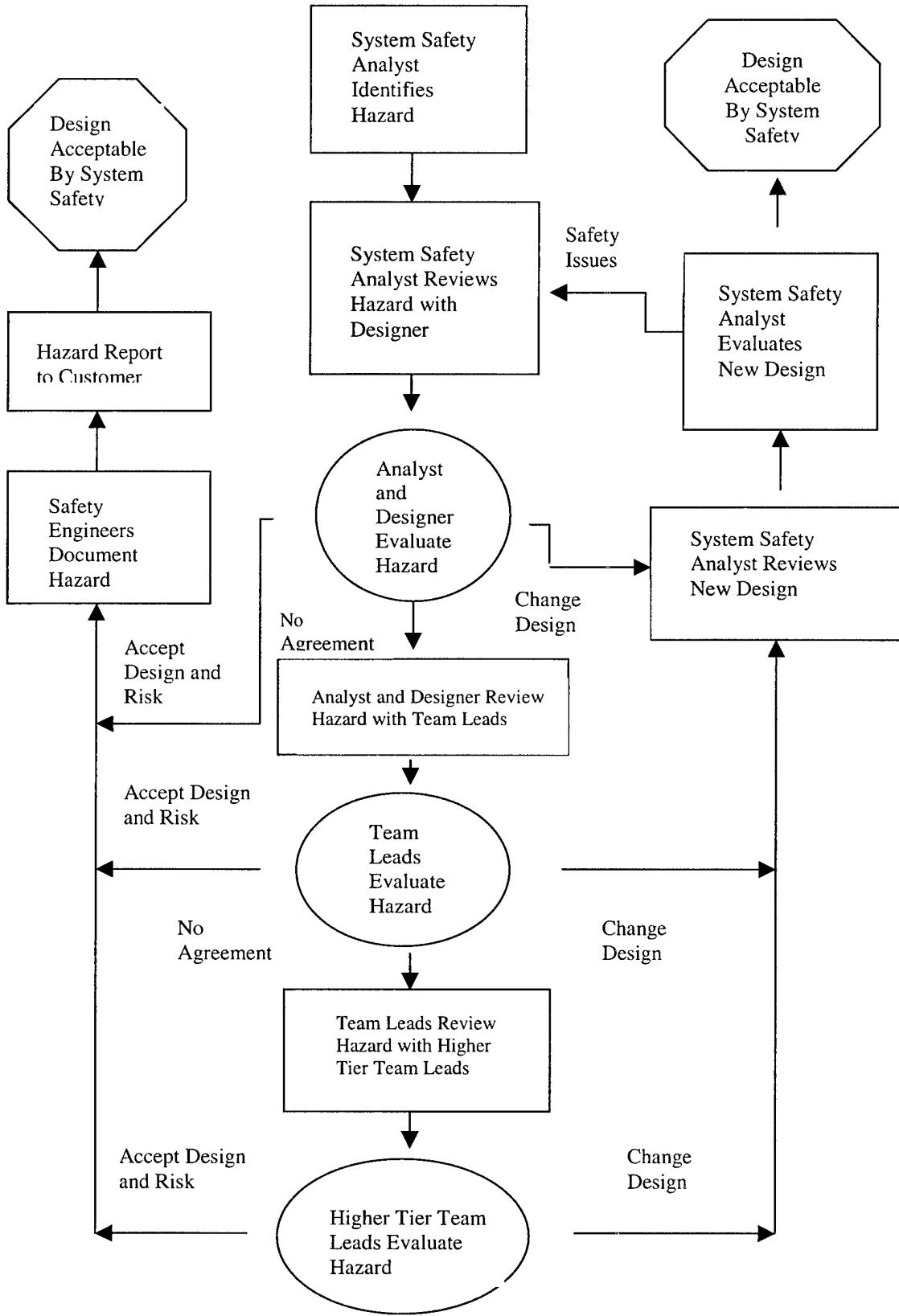

Figure 2.1 Hazard Control Decision Process (Lockheed Martin Tactical Aircraft Systems Report)

2.2.2 Risk Assessment

Hazard severity categories, defined in Table 2.1, and hazard probability levels, defined in Table 2.2, are in accordance with MIL-STD-882C, paragraphs 4.5.1 and 4.5.2. Lockheed Martin Tactical Aircraft Systems (LMTAS) developed a quantitative hazard rate for each probability level, as listed in Table 2.1. The quantitative hazard rates are based on total USAF F-16 fleet flight hours expected to be flown at completion of the F-16 program. Flight fleet hours represent the total hours flown by all USAF F-16s in the fleet. For applications that are not applicable to the entire fleet (e.g., equipment only on certain blocks of aircraft), the proportional number of flight hours can be used to derive the appropriate hazard rates.

Table 2.1 Hazard Severity Categories

Description	Category	Definition
Catastrophic	<i>1</i>	May cause death, system loss, or severe environmental damage.
Critical	<i>2</i>	May cause severe injury, severe occupational illness, or major system or environmental damage.
Marginal	<i>3</i>	May cause minor injury, minor occupational illness, or minor system or environmental damage.
Negligible	<i>4</i>	Will not cause injury, occupational illness, or system or environmental damage.

Any time a hazard is identified that is judged to be inadequately controlled, the procedure in Figure 2.1 is followed.

Table 2.2 Hazard Probability Categories & Rates

Description	Level	Fleet or Inventory	Rate*(Per Flight Hour)
Frequent	A	Continuously Experienced (Greater than 500 Occurrences)	5. 0 E-05 to ∞
Probable	B	Will Occur Frequently (Between 5-500 Occurrences)	5. 0 E-07 to 5. 0 E-05
Occasional	C	Will Occur Several Times (Between 1-5 Occurrences)	1. 0 E-07 to 5. 0 E-07
Remote	D	Unlikely But Can Reasonably Be (Between . 01-1 Occurrences)	1. 0 E-09 to 1. 0 E-07
Improbable	E	Unlikely To Occur, But Possible (Less than . 01 Occurrences)	Less than 1. 0 E-09

**Rate based upon 10,000,000 flight hours for USAF F-16 fleet life. Adjust rate if application is less than fleet life.*

A risk assessment combines the hazard severity and hazard probability. The hazards in Table 2.3 (hazard risk index of 1A, 1B, 1C, 2A, 2B, or 3A), have unacceptable risk and, therefore, require additional hazard controls to reduce their risk. The light shaded hazards in Table 2.3 (hazard risk index of 1D, 2C, 3B, or 3C) have undesirable risk and, therefore, require implementation of the hazard control decision process in Figure 2.1. The unshaded hazards in Table 2.3 (hazard risk index of 1E, 2E, 3D, 3E, 4A, 4B, 4C, 4D, or 4E) have acceptable risk and do not require further action.

Table 2.3 Hazard Risk Assessment Matrix with acceptability criteria

	Catastrophic 1	Critical 2	Marginal 3	Negligible 4
A Frequent	1A**	2A**	3A**	4A
B Probable	1B**	2B**	3B*	4B
C Occasional	1C**	2C*	3C*	4C
D Remote	1D*	2D*	3D	4D
E Improbable	1E	2E	3E	4E

2.3 Combat Capability

There are many documents about combat capability in the literature. The USAF web page is the most important resource for this study. Combat capability is the realized capability of a force at any instant of time to achieve combat results in furtherance of a specific mission against a specific enemy force in a specific combat environment.

Combat capability is accepted as the actual instantaneous force that influences the combat situation (The Nation's Air Force, 2000).

The Air Force usually provides the quickest response and longest-range forces available to the armed forces. The USAF can deter, deploy for influence, or employ with lethal force anywhere in the combat region. Achieving air superiority and conducting precision attacks are key elements in fighting and winning the war. Air superiority includes the ability to protect our forces against any kind of attacks, such as ballistic missile attacks. Precision attack is the combination of precise target acquisition, munitions, and weapons delivery. Increasing combat capability is the main goal for the Air Force acquisition process. The USAF has to pursue modifications that will increase F-16 combat capability (The Nation's Air Force, 2000).

2.4 Operations Cost

Cost is a major concern and a driving factor in the development and operation of a weapon system. Also of concern are the requirements of the system being planned and their relation to overall cost. Developing the connection between requirements and cost quantification is not a trivial problem. The operational costs are those that happen during the project-life. They are not depreciable costs and are used to maintain the whole process in operation. The main items of operations cost are personnel, consumables (parts), and maintenance (Costing and charging for research, 1995).

The decision to field a new system requires a commitment to support that system for years into the future. Decisions to develop, procure, and support new systems are based on many factors, one of which is the projected cost of the systems over their operational lifetime. Operating and support costs normally constitute a major portion of system life-cycle costs and, therefore, are critical to the evaluation of acquisition alternatives.

2.5 Decision Analysis

Selecting the best modifications to enhance the F-16 capabilities is a complex decision problem. Safety, combat capability, and operations costs are different aspects of this decision. Thinking about the tradeoffs easily shows that one cannot simply rely on instinct to decide. The obvious reason for studying decision analysis is that carefully applying its techniques can lead to better decisions (Clemen, 1996: 3).

In general, decision-making involves the following concerns:

- Planning
- Generating a set of alternatives
- Setting priorities
- Choosing a best policy after finding a set of alternatives
- Allocating resources
- Determining requirements
- Predicting outcomes
- Designing systems
- Measuring performance
- Insuring the stability of a system
- Optimizing
- Resolving the conflict

(Saaty, 1990:5)

Each individual decision has its own defining frame. The decision analysis process helps the decision-maker pick the best alternatives within the decision frame. A decision is considered difficult due to:

- Complexity
- Uncertainty in the situation
- Multiple objectives
- Different perspectives and different conclusions.

(Clemen, 1996:3)

Decision analysis provides “ structure and guidance for systematic thinking in difficult situations” (Clemen, 1996:4). Decision analysis is not designed to make the decision for the decision-maker. “The basic presumption of decision analysis is not all to replace the decision-maker’s intuition, to relieve him or her of the obligations in facing the problem, or to be, worst of all competitor to the decision-maker’s personal style of analysis, but to complement, augment and generally work alongside the decision-maker

in exemplifying the nature of the problem. Ultimately, it is of most value if the decision-maker has actually learned something about the problem and his or her own decision-making attitude through the exercise” (Bunn, 1984:8).

The process of decision-making is complicated when dealing with multiple objectives. The problems are complex, and humans commonly rely on intuition to solve problems. Intuition can fail when the decision-maker must make tradeoffs between the competing alternatives. Therefore, we need a well-organized way to make better decisions.

An effective decision-making process will fulfill these six criteria:

- It focuses on what is important.
- It is logical and consistent.
- It acknowledges both subjective and objective factors and blends analytical with intuitive thinking.
- It requires only as much information and analysis as is necessary to resolve a particular dilemma.
- It encourages and guides the gathering of relevant information and informed opinion.
- It is straightforward, reliable, easy to use and flexible.

(Hammond, Keeney, Raiffa , 1999:4)

Figure 2.2 explains the basic steps of the decision-making process.

The techniques for decision analysis can help you make better decisions. However, one should always remember that they do not guarantee that good outcomes will always occur as a result of those decisions. Using a structured approach in making decisions enhances our intuition about the decision problems we face. As a result, it is reasonable to expect better outcomes to occur more frequently when using a structured approach to decision-making than if we make decisions in a haphazard manner (Ragsdale, 2001:714).

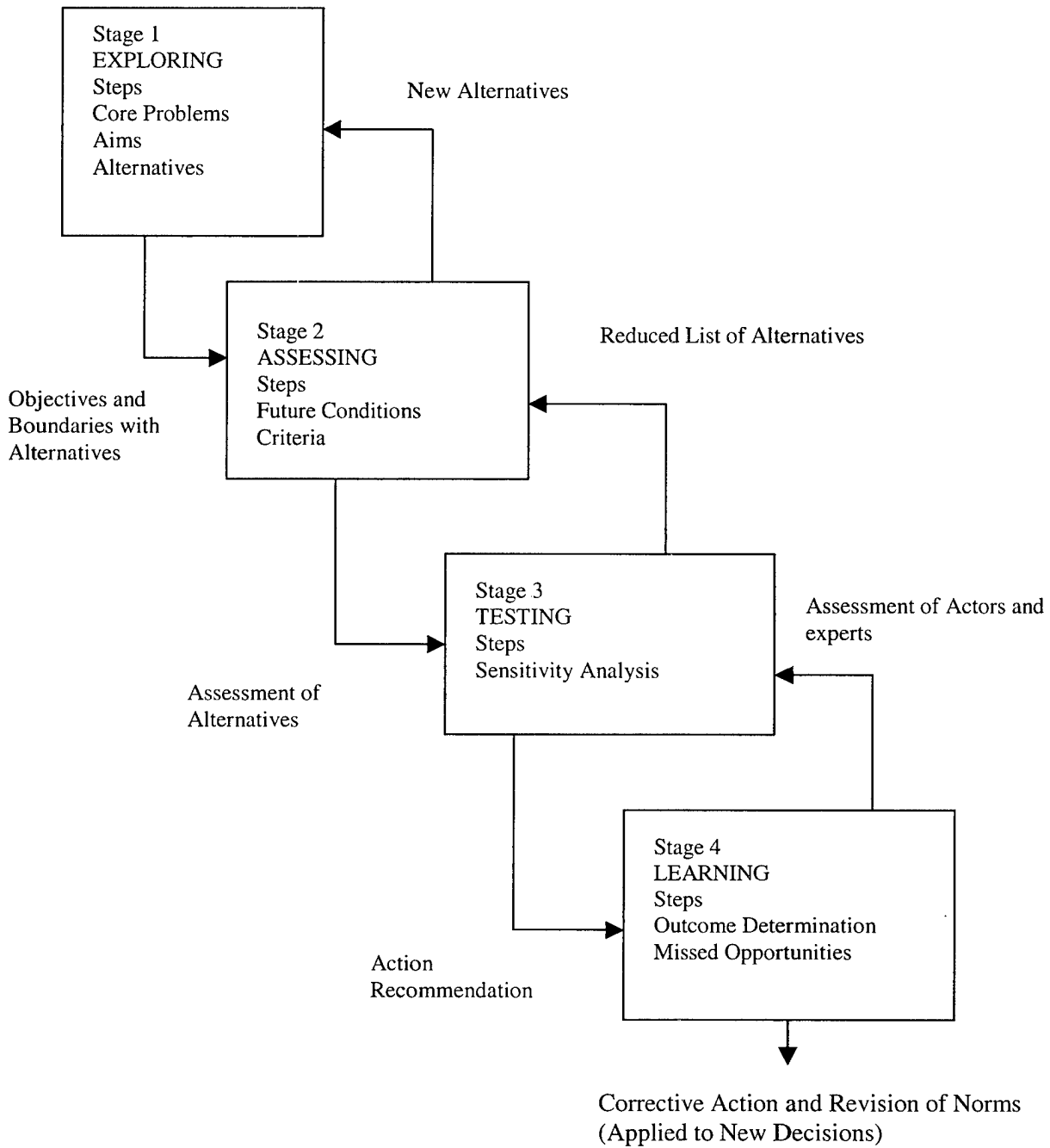

Figure 2.2 The Decision Process (Nutt, 1989 : 408)

2.6 R&D Selection Models

A model is needed to support technology selection for the F-16 system program. Bretschneider (1993) defines two types of analysis in R&D assessments. He defines *ex ante* R&D as those evaluations occurring before any R&D activity and *ex post* R&D as those evaluations occurring after a project has been completed. *Ex ante* analysis focuses on outcomes and impacts and is used to select among competing projects. Based on these definitions, this study is going to be an *ex ante* analysis.

Bretschneider further divide *ex ante* studies into valuation, or benefit measurement models and resource allocation models (Bretschneider , 1993:124).

Valuation models are:

- Models that develop a measure of value through a comparative technique
- Models that are based on obtaining a multidimensional score
- Techniques that link a project's value to the overall economic objective of the firm or organization

Resource Allocation models are:

- Constrained optimization models
- Emulations of organizational and human processes (simulation)
- Ad-hoc in nature

VFT and AHP are two types of multidimensional scoring models. VFT places values in an hierarchical structure and quantifies them with evaluation measures to create a value model. Alternatives are scored using the value model allowing quantification based on achievement of values. AHP, on the other hand, structures priorities. Pairwise comparisons are used to rank the alternatives.

A weakness of VFT is the inability to systematically check for consistency of judgments (Belton, 1986:18). On the other hand, AHP is known to have theoretical

problems. Belton compares VFT with AHP and finds AHP has a major weakness in the manner of asking questions to determine criteria weights and in the assumption that one can use a ratio to compare measurement scores.

Bard (1992) writes that AHP is simpler to use for an inexperienced decision-maker compared to VFT. However, AHP always results in additive weighted value functions and should not be used for risky decisions, where as VFT is not restricted in these ways (Belton, 1986:10), (von Winterfeldt and Edwards, 1986: 275-276). VFT can also create new alternatives that improve the decision context. The ability to create new alternatives prevents the decision context from being “anchored” to narrowly defined alternatives. A VFT value model can be used systematically to probe new alternatives that may be better than those first identified without systematic analysis (Keeney, 1994:38-39).

Cost benefit analysis, rate of return analysis, and risk assessment are the other traditional types of R&D selection models that are in the literature.

2.6.1 Analytical Hierarchy Process

Value function assessments of the model and ranking of the alternatives are not really distinctive with the AHP approach. The decision-maker decides which alternative is better, A or B, within a specific evaluation consideration. The decision-maker uses a nine-point scale to do this comparison. This scale shows the performance of one alternative with respect to another. A mathematical process is used to select the best alternative among the various pairwise comparisons.

The AHP approach uses pairwise comparisons. This is a powerful approach since the human mind excels at making comparisons between two alternatives. Our focus is on decisions where there are two or more objectives in competition and many times those competing objectives require tradeoffs. However, the time for the decision processes to produce the most effective result is equally important.

The AHP process can require a vast amount of time depending on the number of alternatives and/or evaluation measures. Decision models with many alternatives and evaluation measures need a lot of time to make pairwise comparisons. Additionally, decision makers are often inconsistent when making pairwise comparisons between competing alternatives.

Another objection to the AHP is rank reversal, which is considered the most significant flaw in the AHP process. The addition of a new alternative can change the ranking of the existing alternatives, even though the evaluation measures stay the same. It can be shown that rank reversal is normal mathematically. However, the main issue is if rank reversal has a big impact on our decision or not. It is not desirable that the top ranking alternatives change every time something is added or deleted from the model.

Another shortcoming of AHP is the use of approximation methods which impact the given decision. Therefore, the one who has a very important and weight-sensitive decision to make should be careful when using AHP, since the precision of the decision depends on some approximation. Overall, these model deficiencies force a decision-maker to look for another technique.

2.6.2 Value Focused Thinking

VFT is based on the concept of values. Values measure how desirable or undesirable an alternative is, based on the consequences the alternative brings out. Value focused thinking essentially consists of two activities: first deciding what you want and then figuring out how to get it (Keeney, 1992:3-4).

The goal is to incorporate the value into an objective technique for decision-making. Once this is accomplished, we can compare the competing alternatives.

VFT is a *PrOACT* approach to make smart choices. Hammond, Keeney, and Raiffa use *PrOACT* as an abbreviation word for **P**roblem, **O**bjectives, **A**lternatives, **C**onsequences, and **T**radeoffs (Hammond, Keeney, Raiffa, 1999: 7-9).

We can further define each of these terms.

- **Problem:** “What must you decide?” is the most important question to define your problem. The framework of the decision depends on the complexity and assumptions of the problem.
- **Objectives:** It is asking yourself what you most want to accomplish. Your values, interests, and concerns will clear your objectives.
- **Alternatives:** They are different courses of action that you might take. However, you have to understand that your best decision can be no better than your best alternative.
- **Consequences:** Consequences are the answer to the question of “How well do your alternative satisfy your objectives?”. Consequences will help you find the best alternative.

- Tradeoffs: A balance is needed in every decision problem. Setting some priorities between the competing objectives will make the problem easier. Tradeoffs set this balance due to your priorities.

VFT helps you to see both the tangible and intangible aspects of your decision situation more clearly and translate all pertinent facts, feelings, opinions, beliefs, and advice into the best possible choice (Hammond, Keeney, Raiffa, 1999:5).

2.6.2.1 Examples of VFT

A difficult problem for National Aeronautics and Space Administration (NASA) was to choose the future space mission. There were numerous stakeholders involved in addressing multiple uncertainties. The decision required some tradeoffs among the objectives. NASA identified and prioritized their objectives as shown in Table 2.4.

Table 2.4 NASA's Objectives (Keeney , 1998)

Objective	Ranked	Relative
Enhance National Pride	1	100
Aid National Defense	9	20
Promote International Prestige	8	35
Foster International Cooperation	7	40
Create Economic Benefits	5	50
Advance Scientific Knowledge	4	60
Promote Education	6	45
Provide Excitement and Drama	2	90
Maintain Fiscal Responsibility	3	70

The objectives were scored on a scale between 0-100 and ranked depending on their relative importance. The possible alternatives, four different missions, were

compared using the objectives. The missions were ranked in priority order. Tradeoffs among alternatives were discussed. Paired comparisons were made between some competing alternatives using experts' opinions. The results are shown in Table 2.5.

Table 2.5 Ranking of NASA missions in terms of their consequences for each NASA objective

Attribute	A	B	C	D
National Pride	4	3	2	1
National Defense	2	4	1	3
International Prestige	4	3	2	1
International Cooperation	1	2	4	3
Economic Benefits	1	4	2	3
Scientific Knowledge	2	1	3	4
Education and Excellence	3	2	4	1
Excitement and Drama	4	3	2	1
Fiscal Responsibility	1	2	3	4

VFT has been used in many other decision problems. The Department of Energy has used VFT extensively. Transporting nuclear wastes and examining air pollution are some other applications of VFT in the literature.

Many Department of Defense (DoD) agencies have used VFT approach to make decisions in the past. One important VFT study is the safety of landing an aircraft which was done by Yntema and Klem (1965). The safety of landing an aircraft depends on many factors: wind, visibility, ceiling, other aircraft in the vicinity, and so on. Yntema and Klem attempted to quantify the safety of various situations that differed in terms of

ceiling, visibility, and the amount of fuel that would remain at touch down on a normal landing.

The decision-makers were 20 experienced Air Force pilots. The utility functions for ceiling, visibility and, fuel were assessed depending on the pilot's preferences. Each pilot was presented with 40 pairs of consequences and asked to pick the preferable one of each pair. The responses compared with the utility functions. Yntema and Klem concluded that the results were satisfactory (Keeney and Raiffa , 1993:418).

Major Brian Sperling used VFT approach to build a model for consistently evaluating Army aviation hazards in an Air Force Institute of Technology (AFIT) thesis. The model integrated the Army's risk management process and the Director of Army Safety's values into the Army Safety Center's resource allocation process to reduce mishap rates. The model identified the most severe aviation accidents and helped Army Safety Center to define the most valuable controls to reduce these accidents. The study validated the concept of using value focused thinking to rank accidents and hazards while developing a cornerstone for research efforts with the Army Safety Center for a proposed five year plan (Sperling, 1999).

2.6.2.2 Value Hierarchy Development Methods

A value model includes qualitative and quantitative relationships. A value model should be developed from first principles, sound logic, reasoned judgments, and carefully acquired, consistent data (Keeney , 1992:130).

There are several accepted ways to develop value hierarchies. Kirkwood identifies a top down or a bottom up approach as possibilities (Kirkwood, 1997:19-23). The top down approach is used when the alternatives are not well specified. Typically, information for this method comes from mission, vision and strategic documents. The model may be built based on documented information. This process is called the “Gold Standard” when used to develop a value hierarchy (Parnell et.al., 1998:1338)

In the bottom up approach discussed by Kirkwood, alternatives are known and can be examined to determine how they differ from each other. Another approach similar to Kirkwood’s is to determine what task the organization performs with a group of people and name the tasks using verbs. This approach uses the preferences of the experts and decision-makers. If the documentation does not contain enough information to build the model, this approach may be used effectively. This approach is called the “Silver Standard” (Parnell et.al., 1998: 1340). Figure 2.3 shows a value hierarchy model example. Strategic objective is divided into three different objectives. Objectives in the model are made up of different aspects of the decision problem. The lowest level in the value hierarch includes different metrics used for quantifying the alternatives’ achievements (measure of merits). Other terms that are sometimes used for metrics are attribute, evaluation measure, and measure of effectiveness. A metric is used to measure the degree of attainment of an objective.

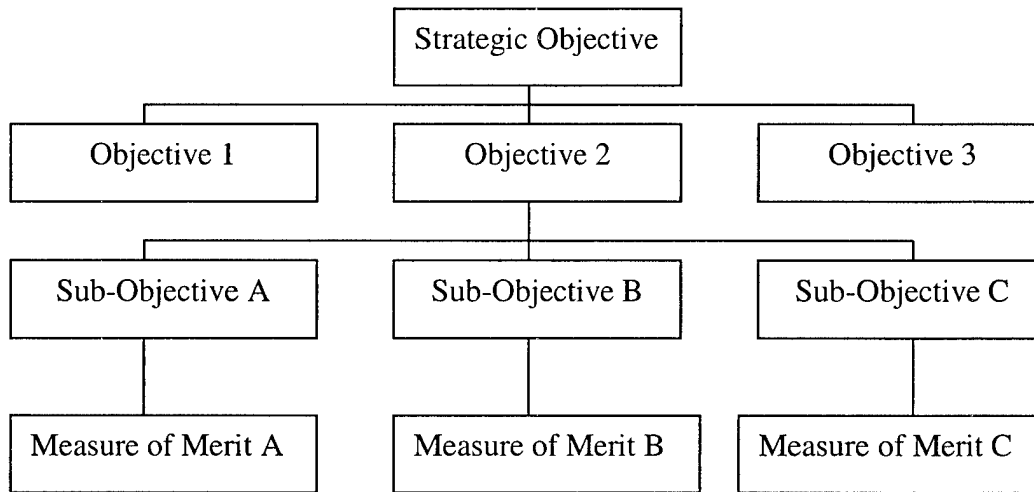

Figure 2.3 Value Hierarchy (Kloeber, Parnell: VFT Brief)

The value model is expected to have various properties to work properly. The desirable properties for a value hierarchy should be completeness, nonredundancy, decomposability, operability, and small size (Kirkwood, 1997:16). Keeney's explanations for the desirable properties of the model are summarized below Keeney(1992).

- **Completeness:** There are two different requirements for a model to be complete: (1) Each tier must adequately cover all concerns necessary to evaluate the overall objective, (2) Lowest tier evaluation considerations adequately measure the degree of attainment of their associated objectives. "A set of objectives is complete if the knowledge of the possible consequences with respect to each of the sub-objectives provides a description of all the implication of interest when an alternative is selected in a decision problem" (Keeney, 1992:58).

- **Nonredundancy:** No two evaluation considerations in the same tier should overlap. A nonredundant (mutually exclusive) hierarchy means that no data in the evaluation are double counted in the model. This can be difficult, because double counting can occur in two ways. One is double counting the possible impacts of the alternatives and the other is double counting the values of those impacts. Eliminating any redundancies reduces the number of objectives and reduces the effort required for data gathering.
- **Decomposability:** The preference of one evaluation consideration should not depend on the other one. Lack of decomposability causes difficulties in the decision-making process, especially for complex decisions. Decomposability means that the aspects of consequences relating to one attribute can be considered independently of the aspects of consequences relating to other attributes.
- **Operability:** The operational properties are concerned with obtaining the information useful for thinking and analysis. The model should be understandable to everybody who will use it. Operability is an issue between specialists and the end users. The model should be easily explained to the end users or the other people related to the process.
- **Small Size:** A small model is easy to use and understand. Thus, it is desirable to have smaller hierarchies, all other things being equal (Kirkwood, 1997:18). A small model is also considered more robust when compared to a bigger one. If the given decision is repetitive with different inputs, then robustness may become a critical issue for the model.

A complete, nonredundant, and decomposable model forms the conjectural background for value focused thinking. An operable and small hierarchy helps the end users to provide better results in shorter periods.

2.6.2.3 Developing Evaluation Measures

Evaluation measures are used to rate of how well an alternative does with respect to each objective (Keeney, 1992:100). Evaluation measures form the x-axis of the metrics. Time, money, and number of peoples are some common evaluation measures' examples used in many studies. Suppose minimizing the loss of life is the fundamental objective of a study. An obvious attribute will be the annual number of fatalities. However, it is not easy to find appropriate evaluation measures for some studies. Different evaluation measures may be needed.

There are essentially three types of evaluation measures:

- Natural evaluation measures: Natural attributes have a common interpretation to everyone. Profit in dollars is a natural evaluation measure for many business decisions.
- Constructed evaluation measures: It is impossible to come with a natural evaluation measure for every objective. Examples of such objectives include “increasing the international prestige of the country”, “improving the image of the corporation”, and “improving the morality of workers”. Improving the morality of the workers' objective can be quantified in an evaluation measure by using three different levels:
 - Bad morality

- Good morality
 - Great morality
- Proxy Attribute: In some cases, it may be necessary to utilize an indirect measure. A proxy evaluation measure reflects the degree of attainment of its associated objective, but does not directly measure this (Kirkwood, 1997:24). The overall objective for an emergency ambulance system might be to “deliver the patient in the best possible conditions”. Since there is no obvious evaluation measure for this decision problem, a proxy evaluation measure is needed. Stevenson (1972) has used the proxy attribute “response time” for this case.

2.6.2.4 Single Dimensional Value Functions

The single dimensional value function converts an evaluation measure into value. Value is typically measured between 0 and 1 (Kirkwood, 1997:61). The scale used for analysis has no effect on the model results as long as the same scale is used for all measures in the value model.

Kirkwood talks about two types of value functions:

- Piecewise Linear Functions
- Exponential functions

Both functions are used in practical applications. The piecewise linear function is easy to use when the evaluation measures have a small number of possible different scoring levels. The piecewise linear single dimensional value function is more widely used by the practitioners of VFT. On the other hand, the exponential function may fit the

preferences of the decision-maker properly for some decision problems. Figure 2.4 shows the examples of both single dimensional value functions.

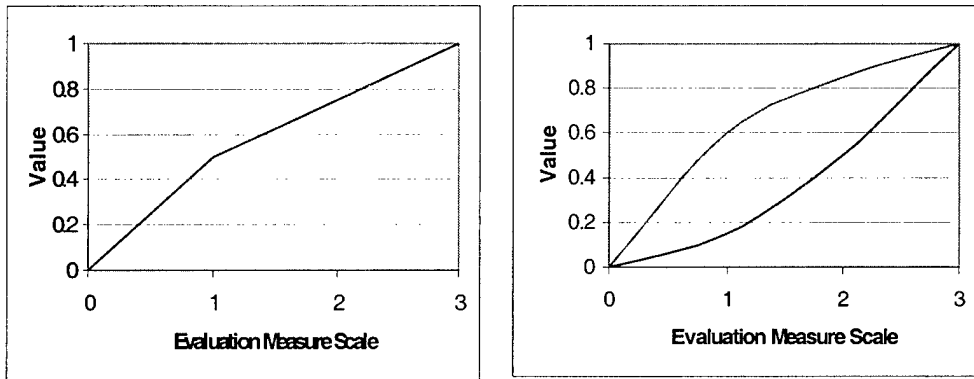

Figure 2.4 Piecewise and Exponential Single Dimensional Value Functions Example

Another form of an evaluation measure with categories is called a discrete value function. Discrete value functions use discrete scoring levels to produce values. A special case of a discrete function is a binary function. An alternative either gets all of the value (1) or none of the value (0) for the function in this situation.

2.6.2.5 Assessing Weights

Many different techniques are used to assess the model weights. Some of them are anchored rating scales, paired comparisons, and direct assignment (Nutt, 1989:413). Each weighting technique has strengths and weaknesses.

The method of swing weights is commonly used to assess the weights for the values in a hierarchy although other methods such as pricing out and lottery weights are

values or measures in the hierarchy is considered individually. The weight for an evaluation measure is equal to the increment in value that is received from moving the score on that evaluation measure from its least preferred level to its most preferred level (Kirkwood, 1997:68). This property provides a base for determining the weights.

Kirkwood provides a small algorithm in his book:

- Step 1: Consider the increments in value that would occur by increasing, swinging each of the evaluation measures from the least preferred end of its range to the most preferred end, and place these increments in order of successively increasing value increments.
- Step 2: Quantitatively scale each of these value increments as a multiple of smallest value increments.
- Step 3: Set the smallest value increment so that the total of all increments is 1.
- Step 4: Use the results of Step 3 to determine the weights for all the evaluation measures (Kirkwood, 1997:70).

A simple example presented in Figure 2.5 explains the swing weights process. Assume that you are trying to assign weights to three values determined to be important when buying a car.

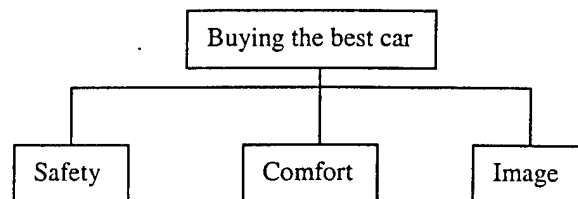

Figure 2.5 Assessing the weights example

The value increments received from moving the score of an evaluation measure from its worst level to its best level while the other evaluation measures are held constant at their worst levels are used to find the weights as mentioned previously. In this case, the decision-maker may tell you that value increment created by changing safety's score from its worst level to its best level is three times as important as comfort's value increment for the fundamental objective and value increment created by changing comfort's score from its worst level to its best level is two times as important as image's value increment for the fundamental objective. "X" defines the smallest value increment in this example. The proportions of the metrics' weights are shown in Figure 2.6.

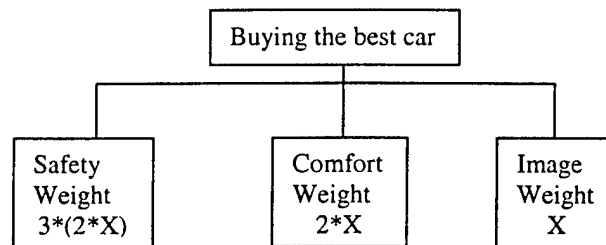

Figure 2.6 Assessing the weights example: Mathematical procedure

The weights can be calculated as follows:

We know that they have to add up to "1".

$$6*X+2*X+X = 1 \Rightarrow 9*X=1 \text{ therefore, } X=0.111$$

Thus the weights are shown below:

$$\text{Safety weight} = 0.666$$

$$\text{Comfort weight} = 0.222$$

$$\text{Image weight} = 0.111$$

2.6.2.6 Finding Alternatives and Attribute Scoring

The decision-maker has to consider two key points:

- You can never choose an alternative you have not considered,
- Your chosen alternative can be no better than the best of the lot.

The VFT approach helps create new alternatives. In this way, better alternatives may be defined for the problem.

Kirkwood (1997) identifies possible methods of improving or finding alternatives. He suggests considering each evaluation measure one at a time and identifying ways to improve the alternative in that particular area. It may be that the alternative is not attractive by improving it in a single area, but the exercise can suggest other attractive alternatives.

Scoring alternatives is straightforward but can be time consuming. The value scores for each attribute are combined using value model weights and the overall value model function. The alternative receives a single measure of merit for the overall fundamental objective being considered for the decision.

2.6.2.7 Ranking of Results

The additive value function incorporates weight and score in calculating the overall value for each alternative. A rank order of alternatives can then be accomplished based on these values. Kirkwood provides information on how to rank results. The graphical techniques used during the process provide insights about the decision problem.

Kirkwood provides implementation methods to determine the contribution each value makes to the scoring of an alternative (Kirkwood, 1996:76-81).

2.6.2.8 Sensitivity Analysis

Exploring how alternative preferences change as the weights assigned to the decision criteria shift is often useful. This gives the decision-maker a justification to act and provides a defense for actions taken (Nutt, 1989:480).

Sensitivity analysis is performed by changing the weight of a single evaluation measure while holding other weights to the same ratio that is defined by the decision-maker. Since all the weights must sum to 1, a particular weight can only change between 0 and 1. If the procedure is insensitive to meaningful variations in the weights, further discussion is not necessary.

2.7 Resource Allocation

Resource allocation decision problems arise whenever there are special funding patterns and new projects have resource requirements which exceed available ones. Bretschneider (1993) notes that constrained optimization models have a set of equations containing decision variables called constraints. The models also contain the objective function, and decision variables. Linear programming, integer programming and nonlinear programming are optimization models typically used in resource allocation decision analysis.

Kirkwood discusses benefit/cost analysis and optimization methods for solving resource allocation problems (Kirkwood, 1996:199). The process calculates the ratio of the benefit of the project to the cost of funding the project. This ratio provides insight based on the benefit per dollar invested. There are some problems with this approach. The model can handle only one constraint, and most practical applications involve more than one constraint.

Baker and Freeland (1975) identify some of the limitations in R&D and resource allocation Models:

- Inadequate treatment of risk and uncertainty
- Inadequate treatment of multiple, often interrelated criteria
- Inadequate treatment of project interrelationships with respect both to value contribution and resource utilization
- No explicit recognition and incorporation of the experience and knowledge of the R&D manager
- The inability to recognize and treat nonmonetary aspects such as establishing and maintaining balance of R&D problem (e.g., basic between basic and applied work, between product and process effort, and between high risk high payoff and moderate or low risk low payoff opportunities)
- Perceptions held by the R&D managers that the models are unnecessarily difficult to understand and use

- Inadequate treatment of the time variant property of data and criteria and the associated problem of consistency in the research program and the research staff

Baker and Freeland conclude that R&D and resource allocation models are incomplete in the sense that they do not include all the important, relevant aspects of the R&D environment. As a result the manager is forced to adjust the recommended allocations in order to account for numerous environmental conditions not included in the model.

2.8 Summary

This chapter introduced the different aspects of the problem. Safety, combat capability, and the cost issues were explained. It reviewed the technology selection models. An in depth review of VFT and AHP were provided. Some previous VFT studies were examined. Finally, the R&D models and their limitations were reviewed to complete the chapter.

Chapter 3: Methodology

3.1 Introduction

Different types of R&D technology selection models were discussed in Chapter 2. The main goal of this study is to select the best set of modifications for F-16 capability enhancement. Multidimensional scoring models provide the most appropriate approach for the study since R&D is multidimensional. Many multidimensional R&D models have been used in the past for technology selection problems (Golabi, Kirkwood, Sicherman, 1981). Two types of multidimensional scoring models were discussed (VFT and AHP). VFT was the best fit because it does not have any theoretical problems and limitations known to exist in AHP. VFT also allows development of the new alternatives (Keeney, 1992:38-39) and does not require reevaluation of all its alternatives when a new one is added to the model (Bretschneider, 1993:127-128).

Chapter 3 begins with an explanation of the framework for the study. The second topic covered is the method of developing the value hierarchy. A modified VFT approach is discussed to give a better understanding of the subject in that section. The model is divided into two different sections. The first section is called decision weights. This section helps decision-makers modify their models depending on their preferences. The second section is the value hierarchy model. The values of the decision-maker are explained in the beginning of value discussion. The development of the evaluation measures, weighting the values, value functions, and using the additive value function are

the final parts of the process explained in the second topic. Next the value model is merged to the decision weights to complete the process. The last topic covered is the assumptions and limitations of the model. A summary of the chapter is presented to complete the chapter.

3.2 Analysis Process and Framework

The framework identifying analysis steps needed for modification selection in F-16 model is shown in Figure 3.1. This section summarizes the process. The first step in the study was to identify a value hierarchy for F-16 aircraft, called the F-16 Capability Enhancement Model. F-16 SPO leaders and ASC experts were consulted to confirm, modify, and develop value definitions. Top-down value structuring method was used to build the model. This approach defines the overall objective and divides the overall objective into objectives. Objectives are also divided into sub-objectives to capture the values of the decision-maker in detail. Such an approach is referred to as “objectives-driven” as well (Kirkwood, 1997:21). The final model represents the values for F-16 program in the Air Force. Certain assumptions and limitations of the model will be stated in detail later.

Evaluation measures were developed after the value hierarchy was approved. Piecewise linear and exponential functions were developed according to the decision-maker’s opinion.

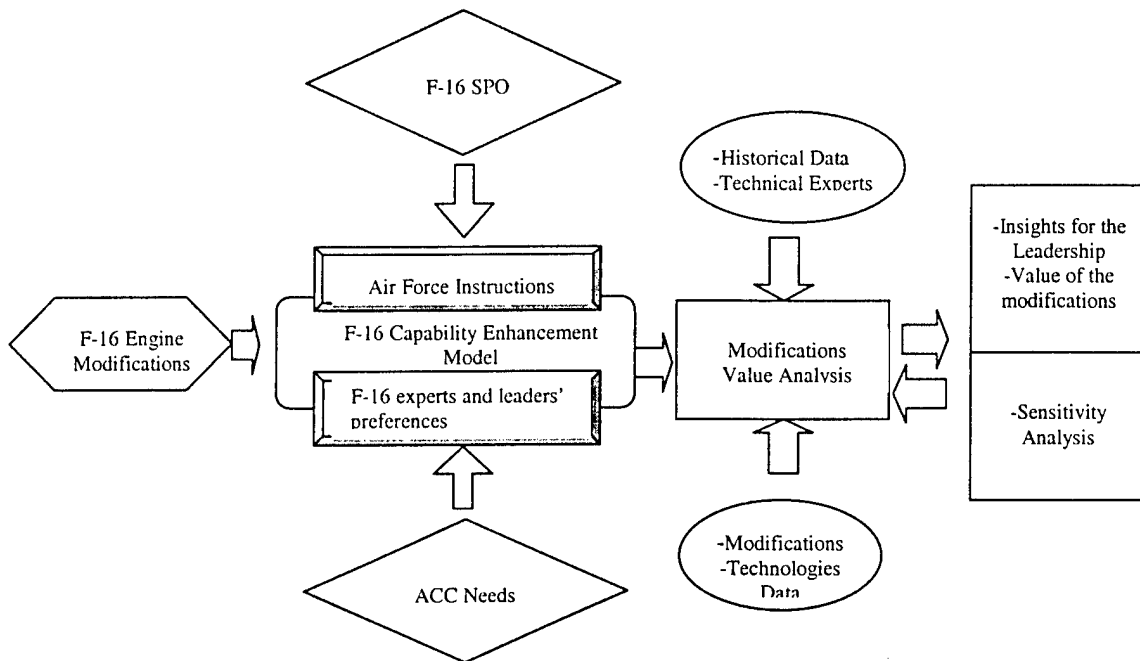

Figure 3.1 Study Framework

The evaluation measures combined with the value hierarchy and weights to define the model. Due to the complexity of data gathering, it was difficult and slow to collect the relevant data for building the evaluation measures.

The modifications were examined as a starting point for alternatives in this study. Since the F-16 SPO has over 100 modifications, a small subset is selected for analysis of the model. Technical experts are used to complete this part of the study. After identifying alternatives, each alternative is scored.

Each alternative's score is changed into a value between 0 and 1 using single dimensional value functions. The overall fundamental objective score is then calculated for each alternative. Graphs are used to show the contribution of each value for each alternative. The alternatives are ranked according to their overall score and sensitivity

analysis is used to determine how changes in the weights affect the results and resulting decision policy.

Procurement cost is used to identify the benefit to F-16 capability per dollar invested for each modification. A new ranking of the alternatives shows the change in the decision policy depending on the money constraint.

Building the evaluation measures, alternative scoring, graphing the results, and sensitivity analysis were implemented by using Microsoft Excel and Logical Decisions. Kirkwood's Excel techniques (Kirkwood, 1997) and some macros were used for the automation of the process.

3.3 Method for the Value Hierarchy

The value model reflects what is important to enhance the capability of the F-16 aircraft. F-16 SPO and other organizations have not previously used a systematic process of decision-making like VFT or AHP. These organizations have used their "values" to make decisions, however they have never used a mathematical model to quantify them. The process of decision-making using VFT must be explained at the beginning of the process to familiarize people with multidimensional scoring models. Neither gold standard nor silver standard are used directly in this study. While the data for the F-16 model is available, no single USAF document is available that includes all values. Existing literature, documents and expert's opinions are used together to fill in the information gaps in the model.

3.4 Building the Value Hierarchy

3.4.1 Introduction

Like many decision analysis studies, our early meetings to develop and refine the value model were time consuming. We began by studying the literature and using past experiences to build the model. Problems of the early value models and their solutions can be found in Appendix B. It is possible that we have a means objective model instead of an ends objective model, since the final decision-maker (ACC/DR) could not participate in the model development process. While the values of ACC/DR might differ, the mean objectives are important because they lead to achievement of the fundamental objective to enhance the capability of the F-16 aircraft.

A modified VFT approach was accepted as the best solution to our problems. The next section explains the value model and approach in detail.

3.4.2 Building the Model

Figure 3.2 shows the final value model. We show the model two different sections:

- Top tier (decision weights)
- Value hierarchy model

The top tier helps the decision-maker to justify the model for the changing preferences of the decision-maker. These weights can be used for many different purposes due to the aircraft block. This model can quantify the achievement of different alternatives for

various purposes. The model can change the benefits of alternatives for altering decision weights due to modified aircraft blocks. Appendix B explains the purpose of decision weights in detail.

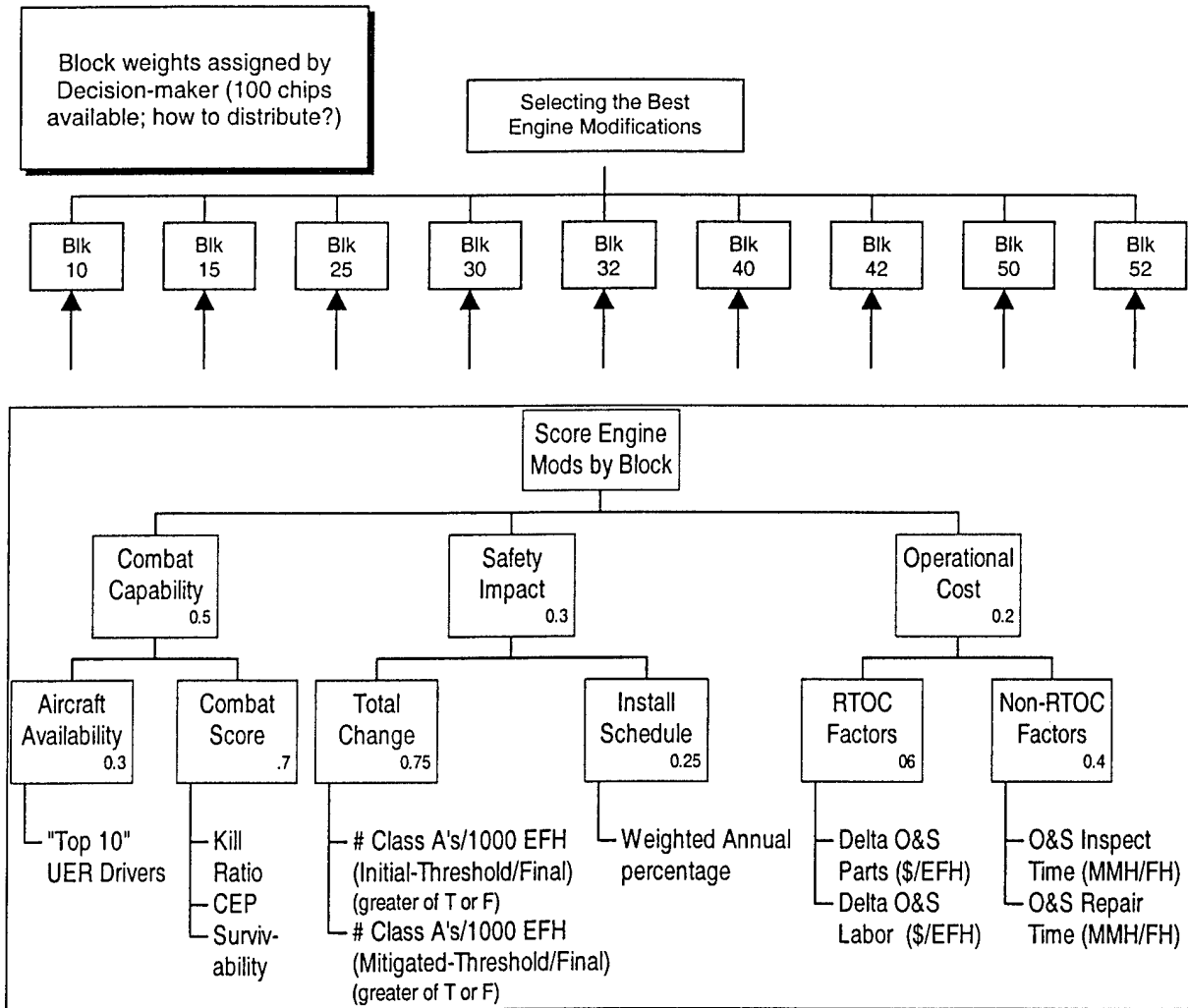

Figure 3.2 Final Model and Modified VFT Approach

The data for modifications that affect multiple blocks are divided into the data specific for each individual block. The model quantifies each specific block data. An

engine score for each block type helps identify the contribution each block makes to the overall engine modification. The next step is assigning the block weights (decision weights) of the top tier. These weights are assigned by the decision-maker. Multiplying the weights with the total scores for each block gives the overall block value. These block values are added together to find an overall alternative score. Ranking is the final step in the model. A simple example in Figure 3.3 describes the process better.

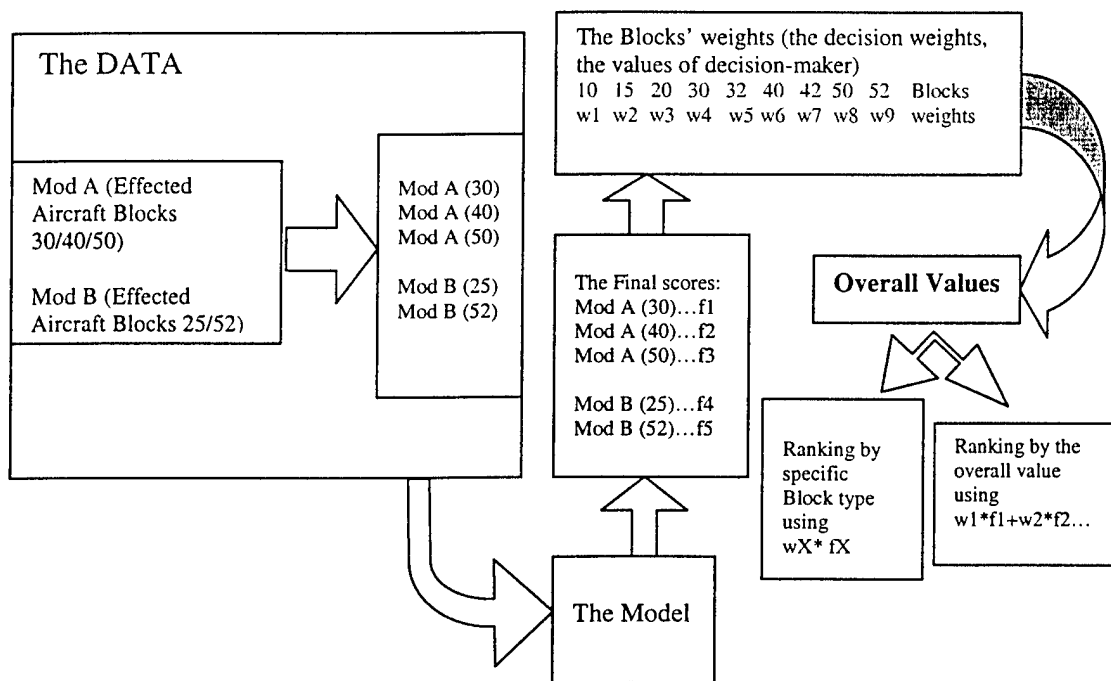

Figure 3.3 Modified VFT Approach Example

The modification data is broken into the specific block type data (e.g. modification A(30), modification A(40), etc.) for each block type affected by the modification. The data is run through the model to get the final scores, f1,f2, etc.. The

decision-maker assigns the decision weights for the top tier ($w_1, w_2 \dots$ etc.). The overall value can be used for different ranking processes, $w_X * f_X$ for specific block type and $\sum w_X * f_X$ for the overall value of modifications.

The accuracy and flexibility of the model enabled the decision-maker's opinions about the aircraft blocks to be blended with the analytical methods of VFT. We accept this approach as the solution to the problems.

3.5 Model Definitions

Building the model was the most critical part of the study. The results are based on multiple meetings and long discussions about "values". The model is not intended to be a means-objective model. However, there may be certain values that cannot be captured or clearly defined due to time and decision-maker constraints.

The overall value (the fundamental objective) is selecting the best set of best engine modifications to enhance F-16 capability. Best is defined as having a higher model score and having a bigger ratio in value/cost analysis when compared to others modifications. Only engine modifications are considered due to time and data constraints involved in evaluating all modifications. However, the study proved that VFT can be applied to ACC's decision-making process as a support system.

The overall value was divided into three objectives as shown in Figure 3.4. The bold portion of the model identifies the current section being discussed.

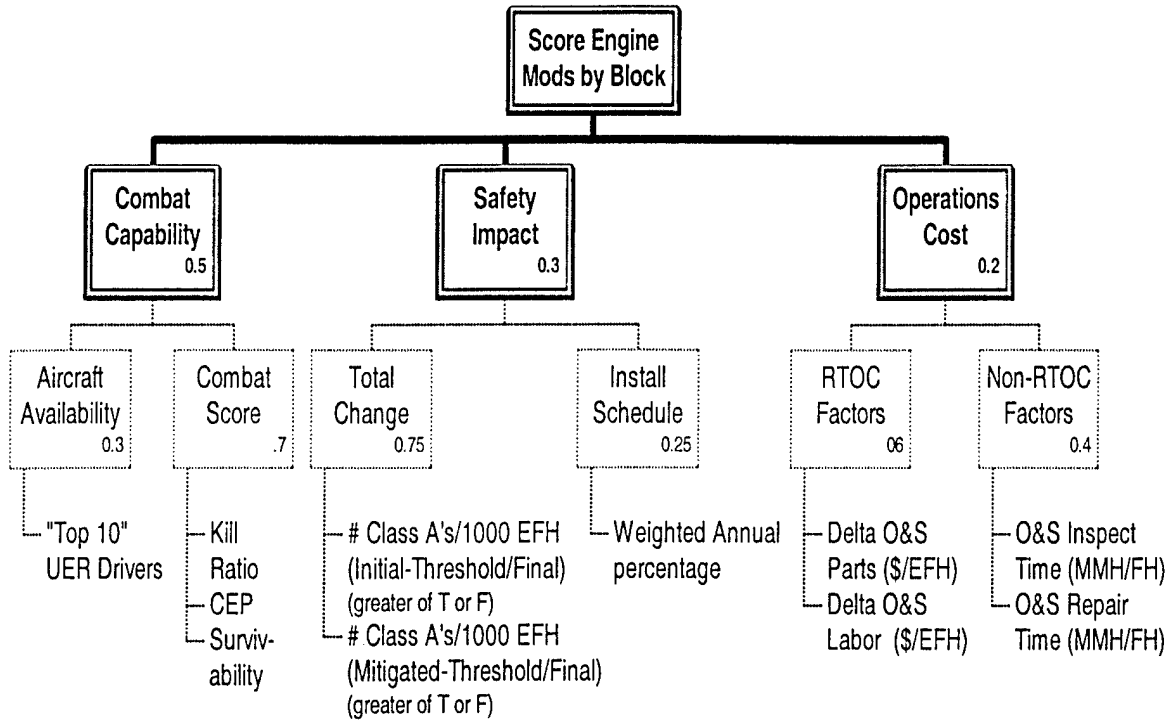

Figure 3.4 Objectives of the Model

First, the combat capability objective of the value model is explained. Next, sub-objectives are discussed under combat capability objective. Evaluation measures of combat capability are introduced to fill the meaning of the combat capability as a value of the decision-maker. Simple examples of some discussions help to understand the true meaning of the objective. Safety impact and operational costs are also explained in the same manner respectively.

3.5.1 Combat Capability

Combat capability is considered to be a heavily weighted part of the model.

The intent of this objective is to capture the increased combat capability that the modification provides for the F-16 aircraft.

As explained earlier, achieving air superiority and conducting precision attacks are the key elements in fighting and winning the war (The Nation's Air Force, 2000). Achieving air superiority and conducting precision attacks provide the base for combat capability. Representatives from F-16 SPO, AFIT, and ASC worked as a decision team. The team tried to concentrate on these two goals for the study. However, the discussion about what they mean to F-16 aircraft was limited in scope due to the time and data constraints.

The team came up with two different statements to capture the importance of air superiority and precision attacks:

- Aircraft must be ready for takeoff on the runway.
- The goal is to fly the mission, kill our enemy's fighters in air-to-air combat, bomb the targets, and fly back to the base.

The combat capability objective, as shown in Figure 3.5, was divided into two different sub-objectives under the lights of these two statements:

- Aircraft Availability
- Combat Score

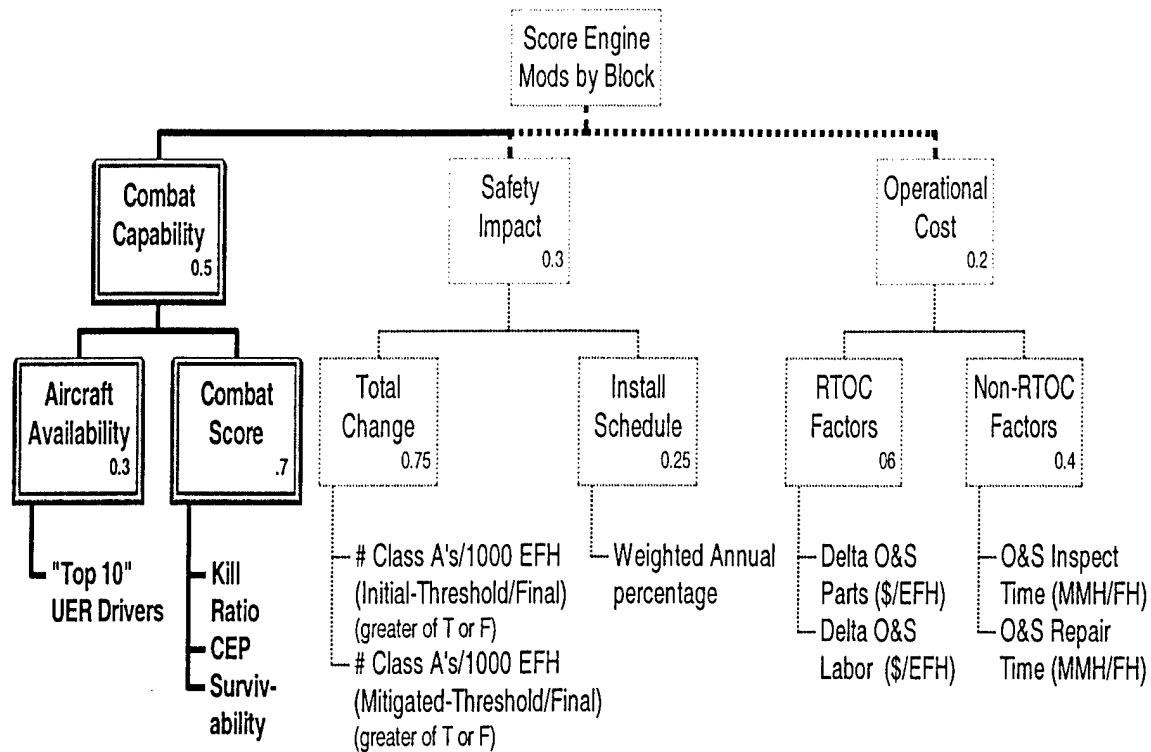

Figure 3.5 Combat Capability

3.5.1.1 Aircraft Availability

The aircraft availability model used by ACC was not the model used for the study. Instead, a simple but effective metric was needed to find the availability of aircraft to carry out the mission.

Studies and experience show that unscheduled engine removals (UER) is a valuable and effective metric for the value hierarchy model. Interviews with engine maintenance personnel show that the biggest impact for aircraft availability comes from UER drivers, as a UER process took about 16-hours (Bullerman, 2000). Other

maintenance procedures are mainly scheduled and short processes. Therefore, UER data was selected as a good metric for the study. This metric dominated all others.

3.5.1.2 Combat Score

Combat score is intended to capture the value of conducting precision attacks. Combat score is the most important sub-objective in the model. The main goal for modernizing fighter aircraft is to keep their combat value up to date. However, it is assumed that engine modifications will not have a big impact on this sub-objective. The engine modifications are focused on fixing or removing documented defects that decrease flight safety. Therefore, combat score is briefly discussed, but does not have a weight in the model due to the scope of this research. However, three different metrics were defined for the completeness of the model:

- **Kill Ratio:** The kill ratio is an air-to-air combat metric that measures the number of enemy aircraft that are destroyed per USAF aircraft loss. Kill ratio depends mainly on the weapon system capabilities of the fighter. Smart air-to-air weapon systems have increased the kill ratio of the F-16 in recent years. The F-16 air superiority capabilities were proven in the Gulf War. One of the main reasons for building the F-16 was to improve on the poor kill ratio of former fighter aircraft like the F-4. Increasing kill ratio is one of the main drivers for ACC to enhance the capability of the F-16 fighter.

- **Circular Error Probability (CEP):** CEP is an air to ground metric that measures bombing accuracy with lower CEP indicating a more accurate weapon system. CEP is defined as the radius from target into which a munition can be placed at least half the

time (Smart Munitions, 2000). This value is also a part of the weapon system. Smart weapon systems are designed to decrease the CEP and improve bombing accuracy for the fighter aircraft. It is one of the main considerations for ACC. The radar guided weapon systems in F-16 increases its bombing accuracy and permits the pilot drop bombs in bad weather conditions without even seeing the target. The system collects the relevant weather data (like wind) and guides the weapon system due to data changes. This capability makes aircraft a perfect air-to-ground weapon system. Based on these reasons, the modernization of air to ground weapon system is an important concern for ACC.

- **Survivability:** Survivability is the increased capability that a modification provides to prevent a combat loss. Survivability features include:

- Small size
- Small trace on the radar screen
- High sustained speeds
- High agility
- Situation awareness features
- Countermeasures equipment
- Buried fuel lines
- Fuel inerting
- Critical systems redundancy and shielding
- Rugged nine-g structure with alternate load paths

The F-16 has lethal self-defense against air threats with features such as radar, guns, all-aspect air-to-air missiles, electronic warfare suites, and towed decoys (Fighter Programs, 2000).

3.5.2 Safety Impact

Safety impact is considered the second most important concern in the model. The goal is to quantify the effect of a particular modification on flight safety. The question

was, “What was the best measure for capturing the impact to flight safety?” Detailed studies point to Class A mishap rates (per 100K flight hours) as the best measure for the risk evaluation.

The mishap classes are labeled A, B, and C. Class A refers to mishaps resulting in fatality, destroyed aircraft or more than \$1 million in damage. Class B includes those resulting in permanent partial injury or more than \$200,000 in damage. Class C, the most common class of mishap, are those resulting in hospitalization or more than \$10,000 in damage (Air Force Instruction 91-204, 29 Nov 1999). Class A mishap rate is an effective measure because it captures the values of the decision-maker, it is easily derivable, and it is a well-known value in the Air Force organizations.

Another important aspect of the safety benefit of a modification is the time it takes to incorporate the modification into the fleet. Installation schedule for the modifications is used to capture our concerns for the time. A simple example outlined in Table 3.1 better explains the problem.

Table 3.1 An Example for Installation Schedule

Modification Type	Installation Year Year 1	Installation Year Year 2	Installation Year Year 3	Installation Year Year 4
A	250 Aircraft	100 Aircraft	0 Aircraft	0 Aircraft
B	100 Aircraft	100 Aircraft	100 Aircraft	50 Aircraft
C	0 Aircraft	0 Aircraft	50 Aircraft	300 Aircraft

As shown in Table 3.1, each modification impacts 350 total aircraft. The decision-makers (ASC and F-16 SPO representatives) ranked the modification A-B-C citing a desire to modify as many aircraft as possible in the early years of the project. There are

several reason reasons driving this factor. One reason is the uncertainty about the future; another is political concerns. Modifying a specific number of each engine type, General Electric (GE) and Pratt Whitney (PW), depending on the future use of the aircraft is a political decision. However, the most important issue is the Air Force losing jets every flight year due to well-known problems, and these modifications reduce mishap rates. The team decided that the best case is modifying all the aircraft in the first year. However, this is not always possible due to constraints like money, man-hours ... etc. A new approach is needed to include time considerations in our model.

Considering these different aspects of the problem, we divide safety into two different sub-objectives as shown in Figure 3.6:

- Total Class A mishap rate change
- Installation schedule

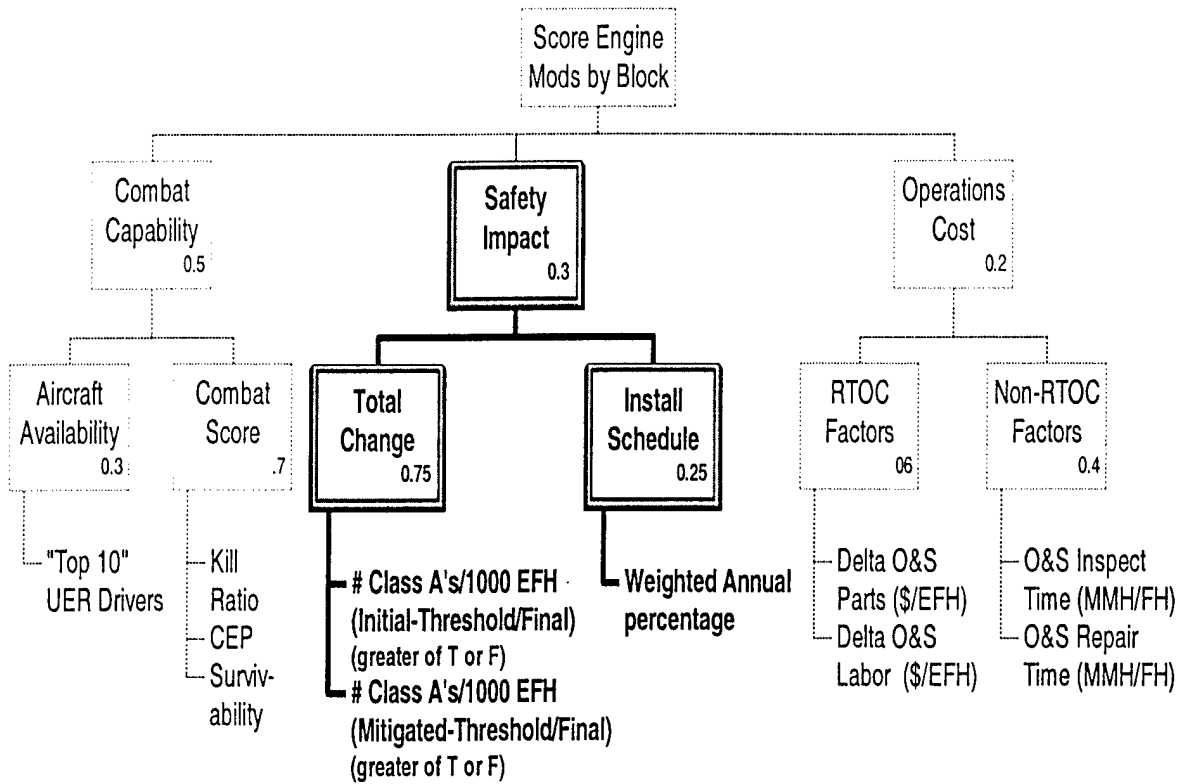

Figure 3.6 Safety Impact

3.5.2.1 Total Class A Mishap Rate Change

Total Class A Mishap Rate Change is designed to capture the decrease in the mishap rate that the modification would provide. Two- different metrics are used for quantifying the alternatives:

- Number of Class A's (Initial-Threshold/Final ,whichever is greater)
- Number of Class A's (Baseline-Threshold/Final ,whichever is greater)

Figure 3.7 helps the reader to understand these two metrics and correlate with the definitions provided.

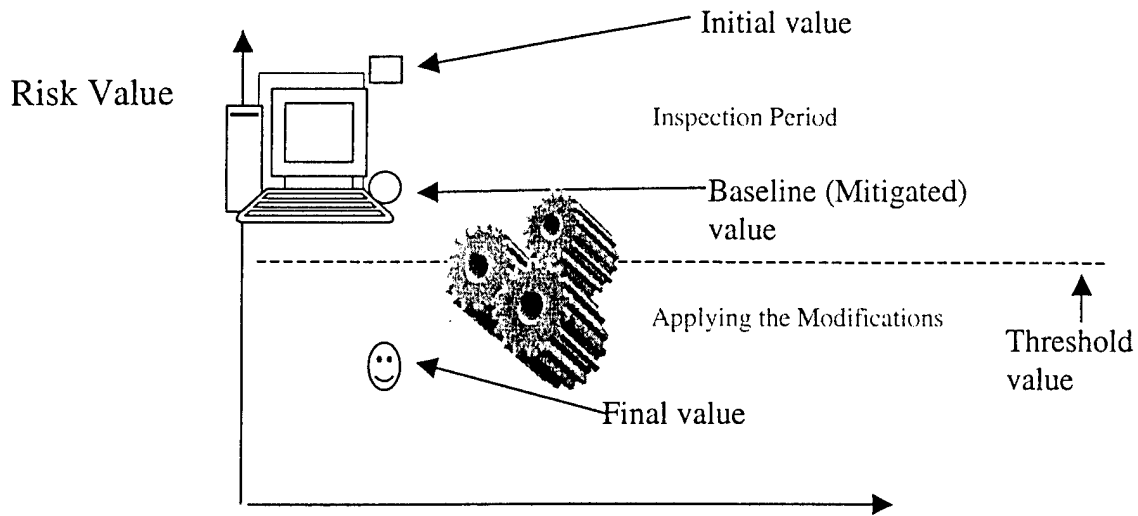

Figure 3.7 Risk

A several definitions help to clarify the example.

- Initial risk: This is the risk value before inspection and installation of the modification (unmitigated risk).
 - Baseline (Mitigated) risk: This is the value of risk after inspection. If the inspection is done an infinite number of times, hypothetically you can reduce the risk to a value close to 0. This is impossible due to constraints like money, man-hours ...etc.
- Therefore, the number of part inspections are traded off against money and time.
- Threshold risk: This value is defined by F-16 SPO for different engine failure types.
 - Final Risk: This is the value after modification installed to the aircraft.

Inspection is a part of the process.

After understanding these definitions, the metrics were constructed to quantify the alternatives.

The first metric, Initial-Threshold/Final whichever is greater, captures the total difference in risk by Class A accidents. The bigger the difference, the more important the modification is to the F-16 community. The team answered the question of why initial risk was important easily. A big initial risk means that aircraft are being lost due to that specific problem. To fix the problem the modification should have a greater value.

The second metric, Baseline-Threshold/Final whichever is greater, gives information about the difference between the inspected and the final value of Class A accidents. One of the main concerns in that area is how to handle the inspection issue. If hypothetically, the aircraft can be inspected an infinite number of times, the risk value is close to 0. However, this obviously is not an option. Increasing the inspection rate increases cost, and is time consuming. Therefore, the current number of inspections and mitigated values are used as the baseline. Another point the team tried to capture is the mitigated risk being equal to the threshold. The ASC and F-16 SPO are not willing to choose the modifications for safety reasons alone in that case. The bigger the difference, the better the modification because there was more risk that was not being mitigated by inspections.

There is only one important question left to answer to justify the metrics: “ Why did we want to use Threshold/Final, whichever is greater?”

A lot of questions were asked to the decision-maker during this process. They are basic why and lottery questions. One of the points during those conversations is especially surprising. The decision-maker said that the difference between final value and threshold was not important. If a final risk value is smaller than the threshold, how much you are under the threshold does not affect the modification selection process at all.

If a final risk value is larger than the threshold, it is due to the other considerations beyond the modification capability. Thus, the word greater is used to handle these situations.

Another point should be clarified to help future studies. The decision-maker was asked if these two different modifications were equally preferred without considering the initial and final value. The answer was *yes* as they were concerned with the total change in risk. This would require a new metric to be developed for capturing the final risk value. However, the team believed that our metrics were adequate to cover the needs of this study. Future researchers should further study the relationship between final risk and the threshold value in more detail. Figure 3.8 explains this issue with a simple demonstration.

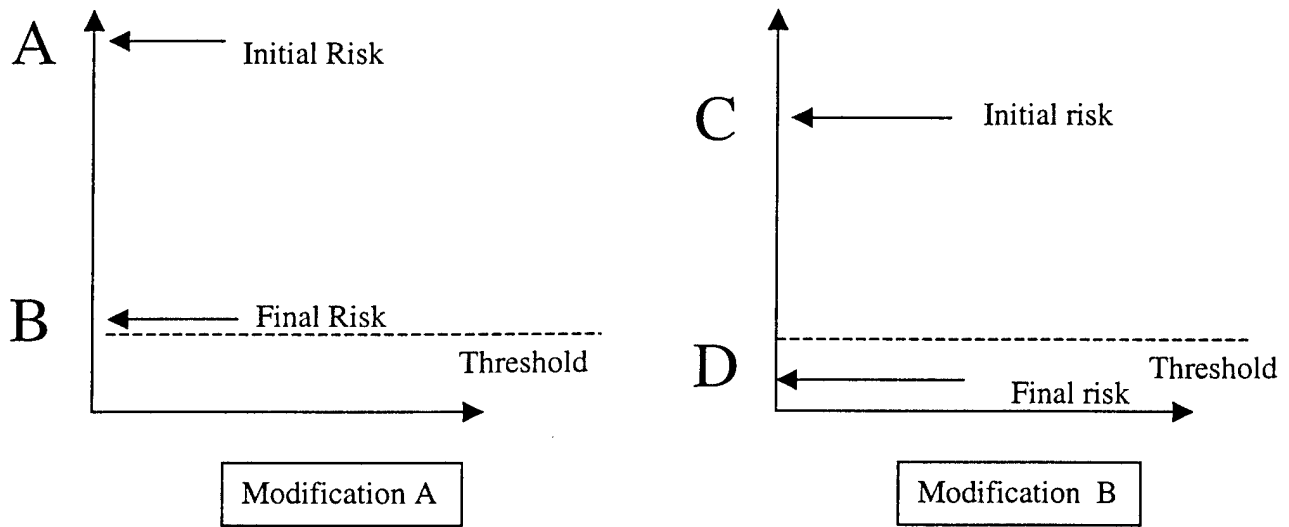

Figure 3.8 A Comparison Example

In this case, $A > C$ and $B > D$ and $A - B = C - D$.

3.5.2.2 Installation Schedule

The time to complete retrofit of the modification and the number of aircraft affected was captured by the installation schedule. The model is expected to penalize long projects due to problems mentioned previously. Further studies are needed to get a better metric for handling this challenging issue.

The team agreed that a modified net present value approach would be useful. This new method is called weighted annual percentage method (WAPM).

There are two main problems:

- The number of aircraft modified per year
- The installation year

The best and worst case hypothetical examples help to get better insights into the problem. Table 3.2 shows hypothetical cases where the number of total aircraft modified is X and the installation schedule is Y years:

Table 3.2 Hypothetical Best and Worst Cases

Modification	Year 1	Year 2 Year Y
Modification A (The Best Case)	X	0	0
Modification B(The Worst Case)	0	0	X

This table is not enough to solve the problem as neither X nor Y are fixed values. The first year is the most important one, therefore, a factor of 1 is chosen for the first year.

The other years take smaller values such as Year 2 has a factor of 0.9, Year 3 has a factor of 0.8 and so on. The normalization for the aircraft number helps to get a score for this specific attribute. Caution is needed at this point, because value function should be between 0 and 1(Keeney, 1992). The value functions are needed and included the weighted annual percentages on the x-axis. A simple example shown in Table 3.3 helps explain the metric.

Table 3.3 An Installation Schedule Example: Aircraft Numbers

Modification	Year 1	Year 2	Year 3	Year 4	Total
A	200	20	40	400	660
B	200	35	50	-	285
C	50	100	-	-	150

Table 3.3 shows 660 aircraft modified in 4 years in the first case. The second case, 285 aircraft are modified in 3 years. The third modification is the shortest one, only 2 years with 150 aircraft modified. Finding the best modification cannot be answered easily. The time and number of aircraft modified per year should be considered. Table 3.4 shows the year factors given by the decision-maker.

Table 3.4 Factoring the Years

Years	1	2	3	4
Factors	1	0.5	0.25	0

These factors reduce the benefit of longer projects. If the project is longer than 3 years, no value is added to improve the alternative's score. An infinite number of year factors

can be found. However, the factors are determined by the decision-maker's representative and will be analyzed during sensitivity analysis.

Normalization, as shown in Table 3.5, is the step before the final result.

Normalizing captures the modified aircraft numbers per year relative to the number of all aircraft modified.

Table 3.5 Normalization Values

Modifications	Normalization Value For Year 1	Normalization Value For Year 2	Normalization Value For Year 3	Normalization Value For Year 4
A	200/660	20/660	40/660	400/660
B	200/285	35/285	50/285	-
C	50/150	100/150	-	-

The final result is demonstrated in Table 3.6. The overall values for years is the multiplication of (modified aircraft number/total aircraft number) times the year factors.

Table 3.6 The Results of Installation Schedule Example

Modifications	Values for Year 1	Values for Year 2	Values for Year 3	Values for Year 4	Total
A	$0.3*1=0.3$	$0.03*0.5=0.015$	$0.06*0.25=0.015$	$0.6*0=0$	0.33
B	$0.7*1=0.7$	$0.12*0.5=0.06$	$0.18*0.25=0.04$	0	0.8
C	$0.33*1=0.33$	$0.66*0.5=0.33$	0	0	0.66

The result of weighted annual percentage technique was acceptable for this case.

Modification B was preferred to Modification C and A. Note that the weights and the values in this process are separate from the VFT process. These calculations help to develop a good metric for the installation schedule. However, sensitivity analysis on this technique provides better insights about the weighting.

3.5.3 Operations Costs

Cost is a major concern in this study. Operations costs are those incurred during the project-life. Operations costs are divided into two sub-objectives as shown in Figure 3.9:

- Reduction in total ownership cost (RTOC)
- Non-RTOC costs

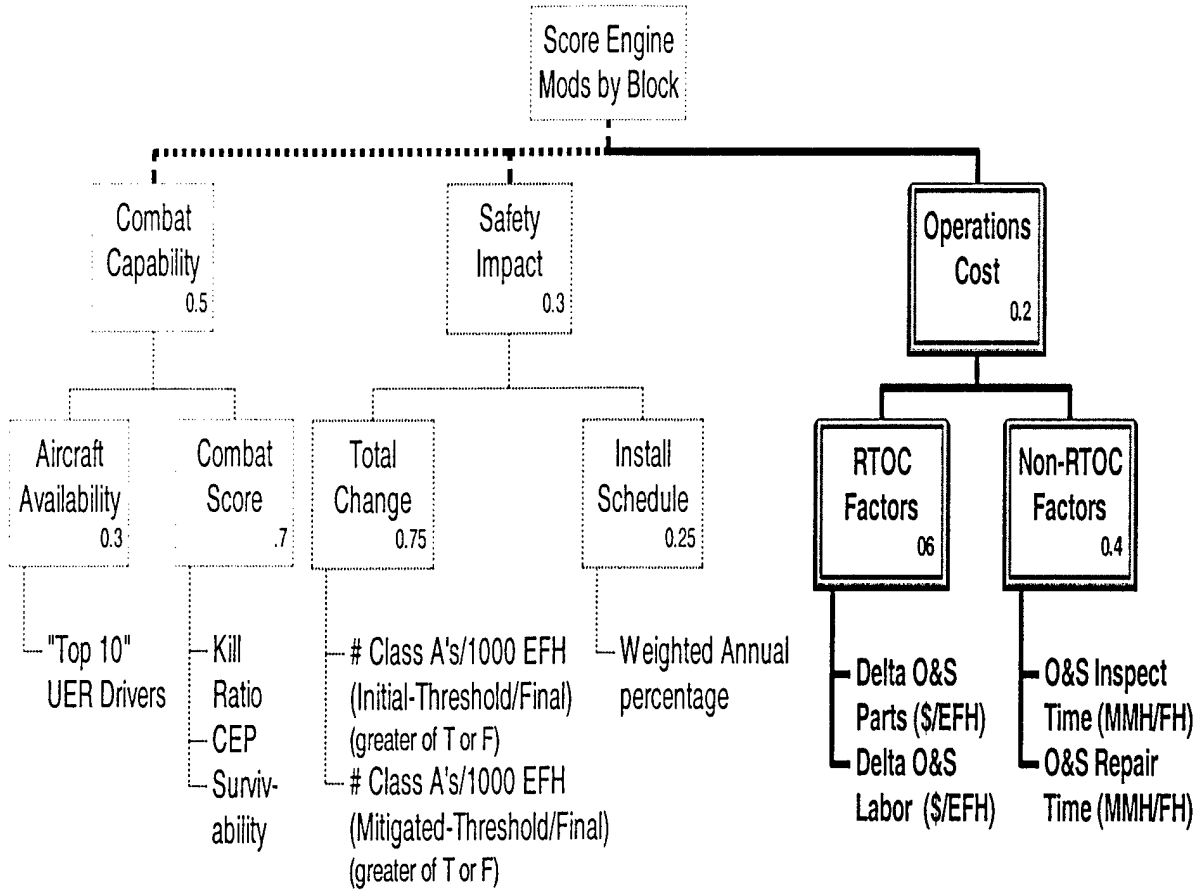

Figure 3.9 Operations Cost

3.5.3.1 RTOC Costs

Reduced total ownership cost (RTOC) is briefly explained to help explain the sub-objectives and metrics used for the operations cost. These two sub-objectives, RTOC and non-RTOC factors, may not include all kinds of cost considerations. However, studying total ownership cost (TOC) and RTOC, shows that a big part of cost consideration for an Air Force project can be captured in an RTOC model. Non- RTOC costs to include the

other main cost drivers in the model. Under Secretary of Defense, Jacques S. Gansler points out the importance of the RTOC model for the Air Force.

We are facing an unprecedented challenge to modernize our forces in a world that demands more efficient as well as more effective acquisition. To meet that challenge, we need to take the next big acquisition reform step--the Revolution in Business Affairs.

For this next phase of acquisition reform, we must further adapt the best world class business and technical practices to our needs, rationalize our infrastructure, restructure our support systems, and reduce cycle times and ownership costs. The Defense System Affordability Council (DSAC) is our forum for setting and monitoring top level goals, objectives, and metrics for these areas--metrics which must be mirrored in each and every DoD acquisition organization, whether it be a program office acquiring a new system or a logistic organization supporting a fielded system.

*The Honorable Jacques S. Gansler,
Under Secretary of Defense (Acquisition and Technology)*

TOC and RTOC concepts are designed to restructure the support systems for making them more effective and efficient.

DoD TOC is comprised of costs to research, develop, acquire, own, operate, train, and dispose of weapon and support systems, other equipment and real property, the costs to recruit, train, retain, separate and otherwise support military and civilian personnel, and all other costs of business operations of the DoD (DESAC Strategic Plan 99).

In the early years of the project, O&S costs are low and return high modernization values. In the process, costs increase while return modernization value decreases to get the same amount of benefit. The modernization provided for the same amount of money begins to decrease in the later years of the project. Figure 3.10 shows the relationship between the modernization and cost.

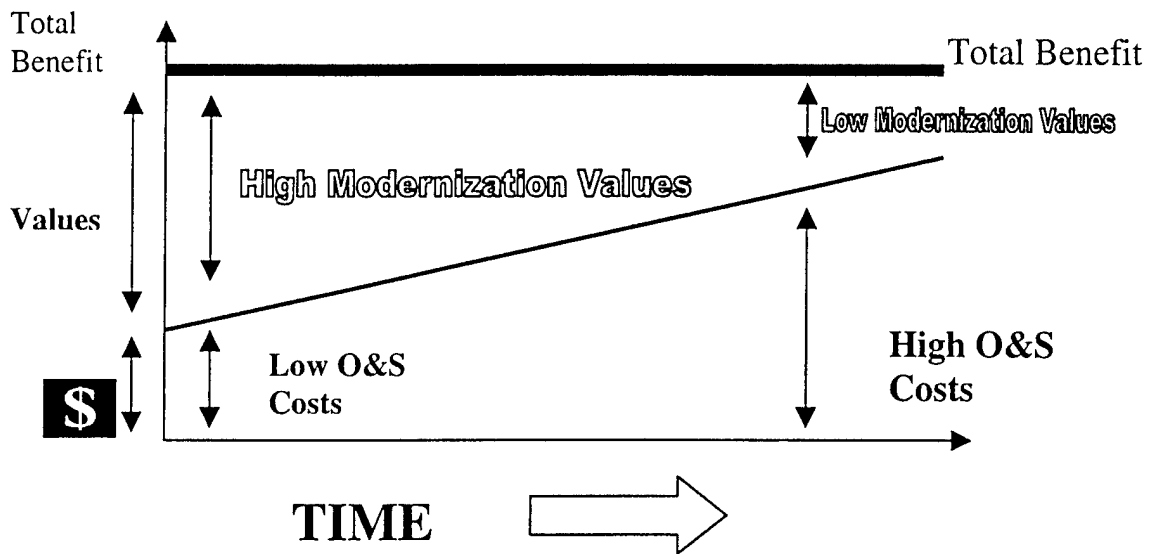

Figure 3.10 Modernization vs. Costs

The RTOC model helps the decision-maker deal with the increased O&S costs in the later years of the project. Sun Tzu's words about TOC are enlightening. Why is TOC important and should be studied? Why must it be controlled and reduced?

As to government expenditures, those due to broken down chariots, worn-out horses, armor and helmets, arrows and crossbows, lances, hand and body shields, draft animals and supply wagons will amount to 60% of the total.

Sun Tzu, The Art of War, 6th Century B. C

The RTOC program is the result of longstanding concern about impact of declining procurement funds, aging inventory and continuing high operations / deployment levels (Dr. Spiros Pallos, RTOC best Practices and Lessons Learned Slides).

Some of the strategic RTOC plans are:

- Investment Strategies
- Effective requirements determination processes
- Implementation of policies to reduce TOC

Air Force uses the RTOC cost model to handle the increased O&S costs of the older systems. Air Force RTOC primary objectives are:

- Cost control
- Cost reduction
- Invest to modernize

(F-16 Offsite RTOC Briefing)

After understanding the importance of the RTOC cost model, the team added two metrics for capturing this value:

- Change in the cost of the parts
- Change in the cost of the labor

These two metrics were accepted as the important drivers which make total cost. Using these metrics is also critical for the model credibility since this study was the first step and RTOC cost model is drawing the attention of the senior leaders.

3.5.3.2 Non-RTOC costs

The other sub-objective is the Non-RTOC costs. Non-RTOC costs are those not included in the RTOC cost model. The most important non-RTOC metrics were O&S inspect time and O&S repair time. However, maintenance man hours (MMH) was used as a proxy metric to cover non-RTOC costs. MMH includes inspection time and repair time for a maintenance problem during the life cycle of a part. One main discussion about this metric was whether to take the total time for MMH, or to use the longest time period. The total time is the sum of separate MMH required for fixing the problems. The

longest one is the maximum MMH required for fixing any problem. Longest time period is more critical, since it affects the F-16 turn around time. It was agreed that turn around time was more important because it was affecting the time on target (TOT). TOT accuracy is accepted as the most important value for the war fighter.

3.6 Single Dimensional Value Functions

Armed with an understanding of each evaluation measure, we present the procedure for determining the single dimensional value functions used in this study. The range for each evaluation measure depends on the historical data. Value functions represent the decision-maker's opinions. Decision-makers for this process were Maj.Kricker (F-16 SPO) and Mr.Hanke (ASC representative). Two different software packages were used for this part of the study. The first one was Microsoft Excel. Kirkwood techniques were implemented using Excel Software (Kirkwood, 1997). Logical Decisions was used for comparing the results during verification. The full data set can be found in Appendix D.

3.6.1 UER Drivers

Historical data shown in Table 3.7 was used to build this value function.

Table 3.7 UER Drivers

UER Driver	Rate / 1000 EFH	Fleet
Stalls	0. 071	-229
FOD/DOD	0. 062	-229
Oil Leaks	0. 060	-229
Turbine Nozzle/Blade Failure	0. 051	-100
Augmentor Liner Deterioration	0. 038	-229
Cracked/Warped Inlet Guide Vanes	0. 036	-100
Flameholder/Fuel Ring Damage	0. 030	-100
Turbine Nozzle Cracks/Failure	0. 027	-129
Turbine Blade/Vane Burn-Through	0. 022	-229
Damaged/Cracked Turbine Frame	0. 018	-129
Component System Malfunctions	0. 018	-100
Broken Safety Wire	0. 009	-129
Turbine Section Deterioration	0. 006	-129
Turbine Blade/Vane Burn-Through	0. 006	-129
Combustor Damage	0. 006	-100

The data represents the occurrences of the UER drivers for specific engine types.

However, they are not modified for aircraft type. This study assumes that the figures are calculated for engines used in F-16. The decision-maker expressed that a linear line was appropriate for this evaluation measure as shown in Figure 3.11. The range varies from zero to 0.071. Zero was added to the range because some alternatives did not attack the UER drivers.

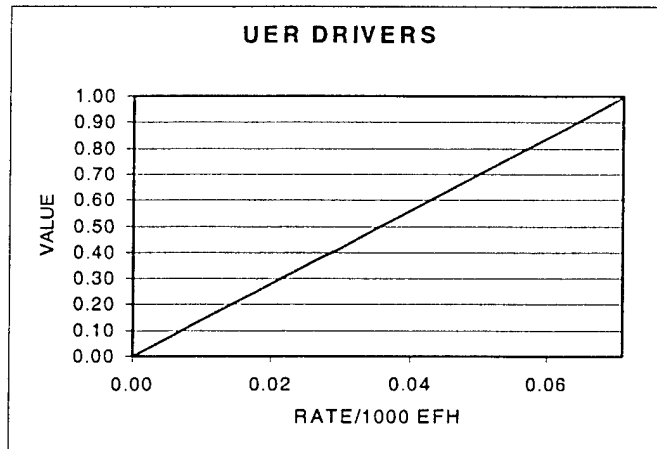

Figure 3.11 UER Drivers

3.6.2 Number of Class A's (Initial – Threshold/Final whichever is greater)

The range for this evaluation measure is from zero to 0.7. The historical data and decision-maker's experience were used for the range. The decision-maker explained that up to a value of 0.1, safety was not a big concern. However, after 0.1, safety was becoming an important issue up to 0.7. He was more concerned with the safety if the score became bigger. This attitude shows that an exponential curve was necessary for that part of the range as seen in Figure 3.12.

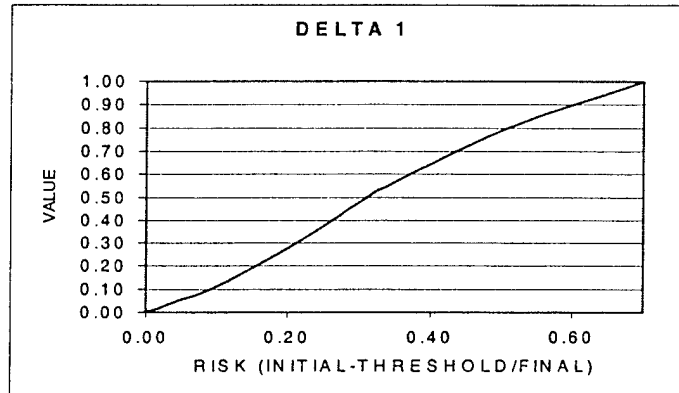

Figure 3.12 Number of Class A's (Initial-Threshold/Final)

3.6.3 Number of Class A's (Mitigated – Threshold/Final whichever is greater)

The range for this evaluation measure varies from zero to 0.7 as well. This range matches the later metric because for some modifications, initial values and mitigated values are the same. Safety experts constructed the mitigated values for these evaluation measures.

The attitude of the decision-maker is similar to the first safety evaluation measure explained above. A simple line is used up to 0.1. However, since this was mitigated risk, the decision-maker was more concerned about the difference. Therefore a slightly steeper exponential function is used as shown in Figure 3.13.

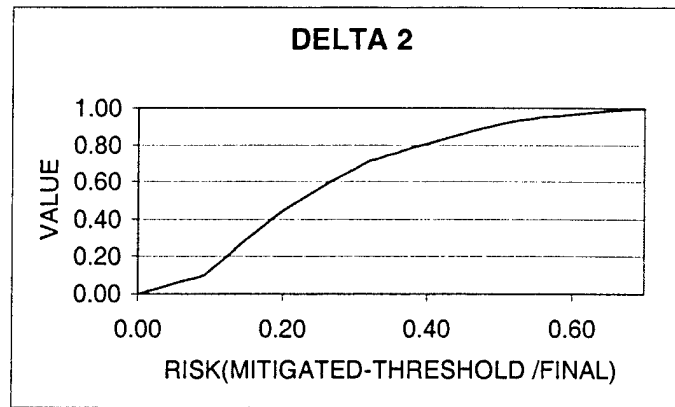

Figure 3.13 Number of Class A's (Initial-Threshold/Final)

3.6.4 Weighted Annual Percentages

The method explained earlier in Chapter 3 is used to get the x-axis values for WAPM. The year factors were determined and every year after 5 gets a factor 0. The factors are 1 for year 1, 0.8 for year 2, 0.6 for year 3, 0.4 for year 4, and 0.2 for year 5. Year factoring values reflect the decision-maker preferences. The calculations for WAPM can be found in the Appendix D.

The range for the WAPM in evaluation measure varies from 0.4 to 1.0. The decision-maker expressed that everything less than 0.4 on the x-axis was equal to a value of zero. An upper bound of 1.0 is used because it is possible to install a modification to all aircraft in the first year (hypothetical best case in Chapter 2). Figure 3.14 shows the value function for weighted annual percentage. The function is linear line since the decision-maker preferences are captured in year factors.

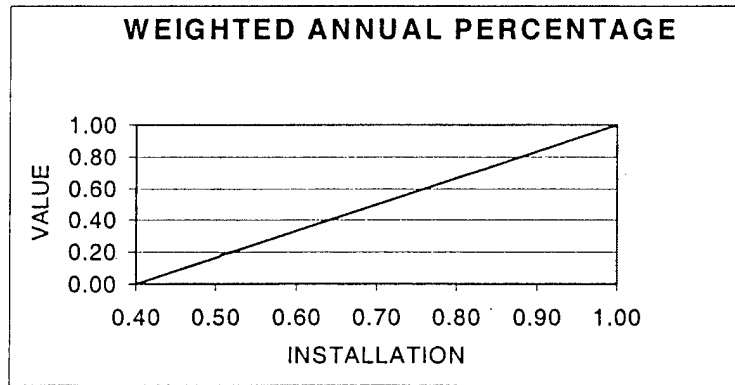

Figure 3.14 Weighted Annual Percentages

3.6.5 Delta O&S Parts

This evaluation measure has a range from \$-1359 to \$100,000. Negative values represent the money that will be spent on the project. The decision-maker expressed that the savings of the parts were insignificant up to \$16,000. After this point however, he said his values were increasing exponentially. An exponential function is considered appropriate to build the value function. However, Kirkwood's exponential function does not work due to the range of the data (Kirkwood, 1997:65). The data had to be modified. The first step involves gathering the entire data set. If the minimum value is negative, the entire data set is shifted by this amount to ensure positive cost values. This is done in the second step. The data are divided with the maximum value to get cost ratios in the third step. The exponential function is now used to derive values for the ratios. Figure 3.15 helps to understand the modification process.

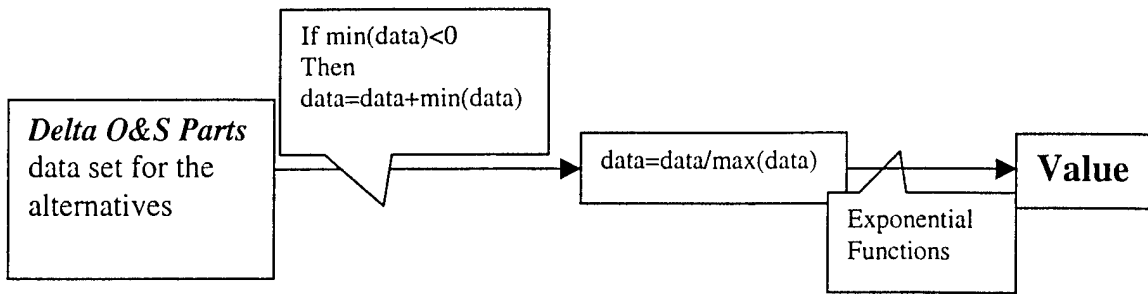

Figure 3.15 Finding the ratios for hardware

Figure 3.16 shows the single dimensional value function for Delta O&S parts.

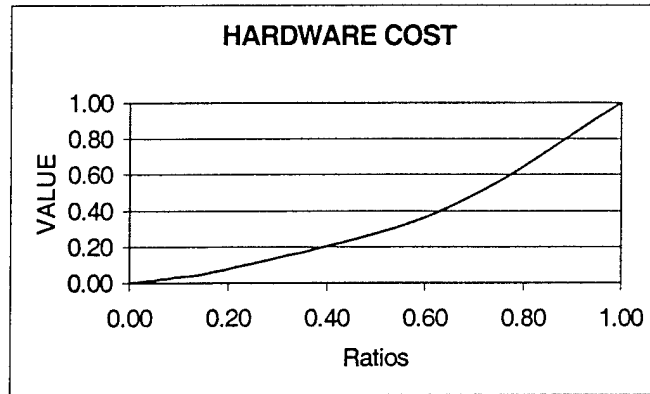

Figure 3.16 Delta O&S Parts

3.6.6 Delta O&S Labor

The range of this evaluation measure varied from \$0 to \$5,000. The decision-maker said that after \$600, his concerns about savings were increasing. The same ratio technique, explained previously, is used for the labor costs. Figure 3.17 shows the single dimensional exponential value function for the metric.

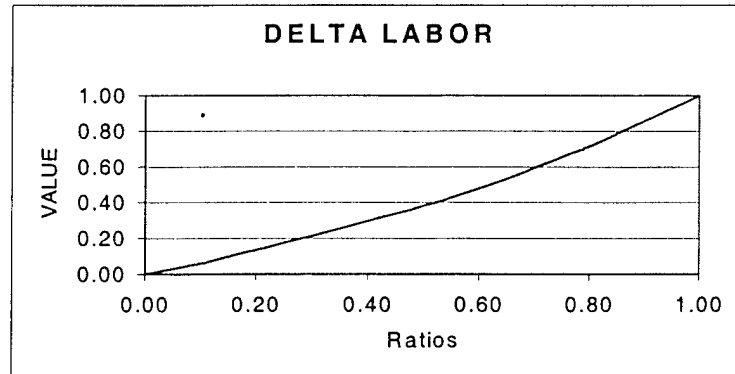

Figure 3.17 Delta O&S Labor

3.6.7 Maintenance Man Hours

Non-RTOC factors were explained previously. O&S inspect time and O&S repair time are constructed to calculate the values. However, O&S inspect time is 0 for many alternatives. Therefore, as discussed earlier maintenance man hours serves as a proxy for these two evaluation measures. Maintenance hours are the sum of inspect and repair time. The costs for MMH are used for the x-axis. This evaluation measure has a value from \$0 to \$600. Fifty dollars is used as the changing point for the concerns of the decision-maker. The ratio method, explained previously, is used to build the value function. Figure 3.18 shows the exponential function for the metric.

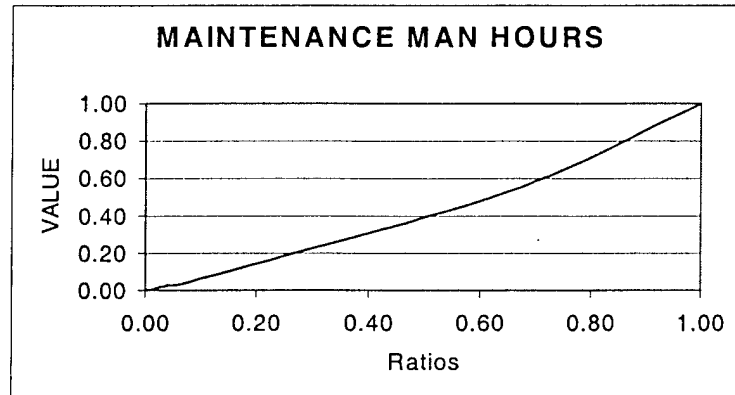

Figure 3.18 Maintenance man hours

3.7 Using Additive Value Function

The additive value function combines the single dimensional value functions that are built by the preferences' of the decision-maker. Equation (Kirkwood, 1997: 243) explains the additive value functions.

$$v(x) = \sum_{i=1}^n W_i * V_i(x)$$

$V(x)$ is used for the overall value of alternative x . W_i is the global weight of i th metric and $V_i(x)$ is defined as the value of alternative x for metric i . Thus, overall value is equal to the sum of multiplication of metrics' global weights and scores of alternatives for each metric. The most important property for an additive value function is mutually preferential independence. The property was checked by Kirkwood's protocol (Kirkwood, 1997: App 7) during the elicitation of metrics phase of the study. The evaluation measures in the same level were fixed to different values (beginning values).

One evaluation measure was increased or decreased while the others were held constant. The decision-maker was asked if it was possible to change the value of an evaluation measure while the others were fixed and if he would change his preference due to this change of the evaluation measure. The purpose is to see if the decision-maker prefers the highest value to the lowest value for each evaluation measure. The decision-maker reported that he would not change his preferences. As a result, the analysis assumed that the model had mutual preferential independence.

3.8 Determining the Weights

It is useful to review some properties of value functions to understand the procedure for determining the weights. Zero is defined as the least preferred level and 1 is defined as the most preferred level for corresponding value function (Kirkwood, 1997:68). This bounds value function between zero and 1.

The weight for an evaluation measure is verbalized as “the value increment that is received from moving the score on that evaluation measure from its least preferred value to its most preferred value” (Kirkwood, 1997:68). The concept is to ask how much value is gained from lowest to highest value in one evaluation measure compared to one another. The procedure is done for evaluation measures on the same level to get rid of the problem of swinging weights. Swinging weights requires the decision-maker to consider the ranges of all the evaluation measures in different levels. The procedure used in the study helped the decision-maker to provide a ratio of importance.

The global weights of the each evaluation measure are used in the additive value function. The difference between local and global weights can be explained in a simple example as shown in Figure 3.19.

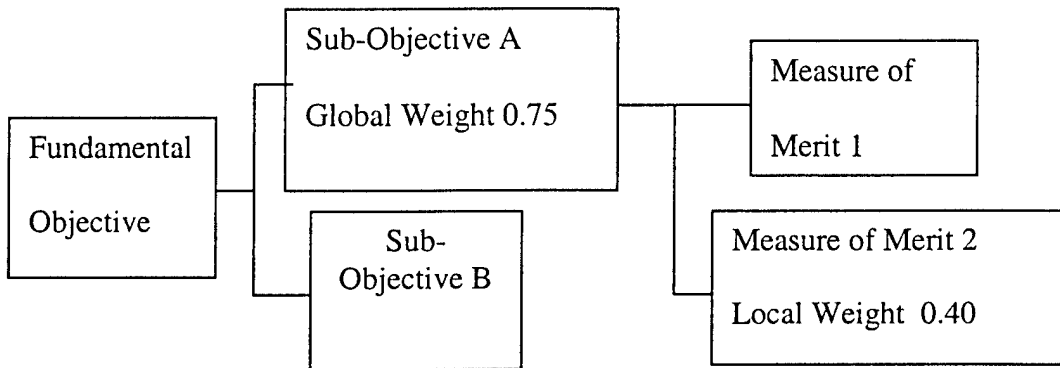

Figure 3.19 Local and Global Weights

The global weight for Measure of Merit 2 =

$$\begin{aligned} &= \text{Local Weight (Measure Merit 2)} * \text{Global Weight (Sub-Objective A)} \\ &= 0.40 * 0.75 \\ &= \mathbf{0.30} \end{aligned}$$

The calculations for weights were done in Logical Decisions. CEP, kill ratio and survivability weights are defined arbitrarily for the model completeness. This does not affect the results of the study because engine modifications do not improve the F-16 combat capability as stated earlier. The weights are shown in Figure 3.20.

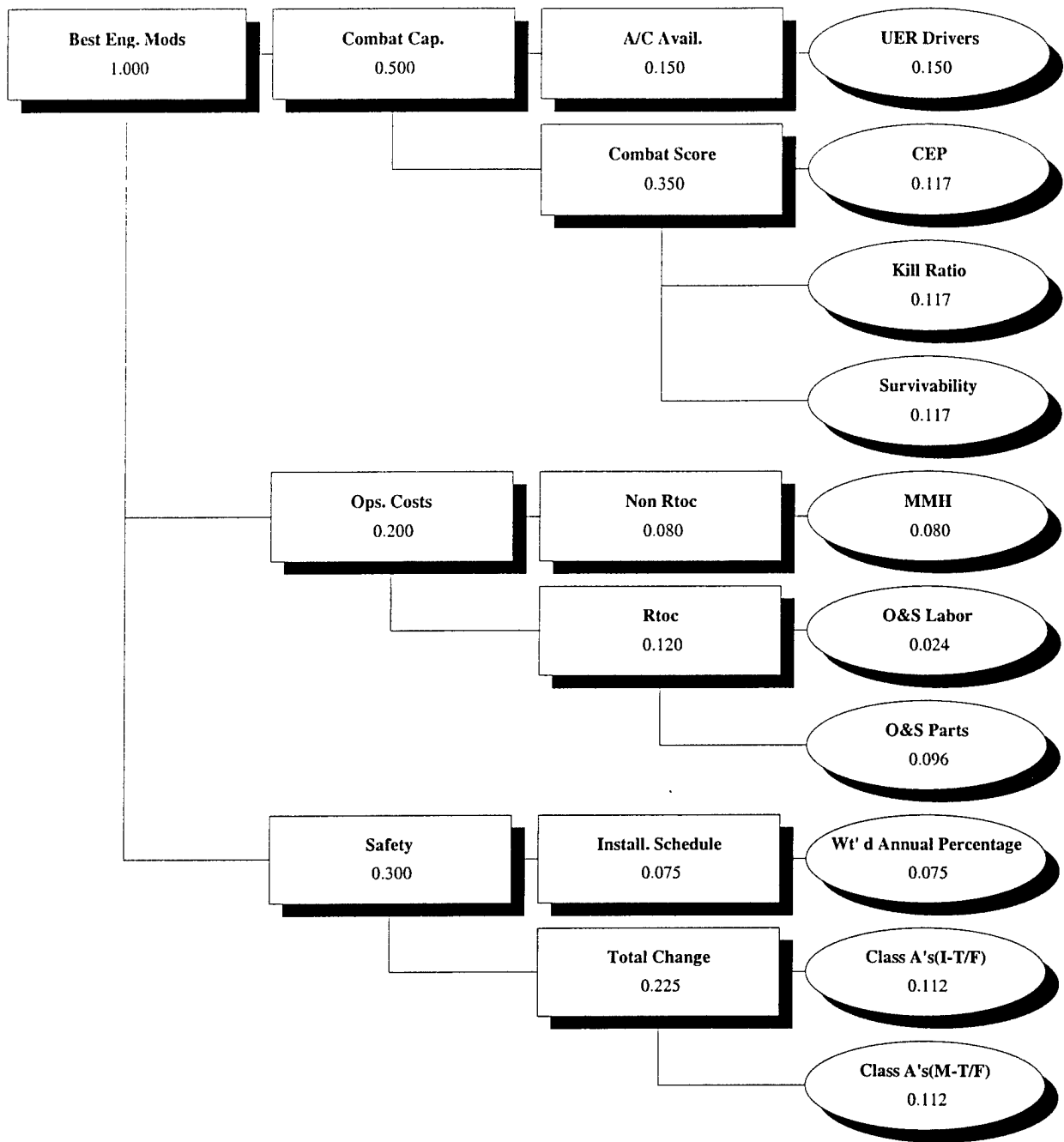

Figure 3.20 Global Weights of the F-16 Capability Enhancement Model

As shown in the previous diagram, the evaluation measure UER drivers have the biggest impact for the overall value. Safety evaluation measures number of Class A accidents

(Initial-Threshold/Final) and number of Class A accidents (Mitigated-Threshold/Final) are other important drivers in the model. However, the differences among the global weights of the evaluation measures are not significant. This property makes our study a true multidimensional decision-making problem. It is not possible to see the winning alternatives without applying the techniques of decision analysis. Figure 3.21 shows the impact of the evaluation measures on the overall value model. This figure shows the proportional relative importance of the evaluation measures when CEP, kill ratio and survivability are not included in the model.

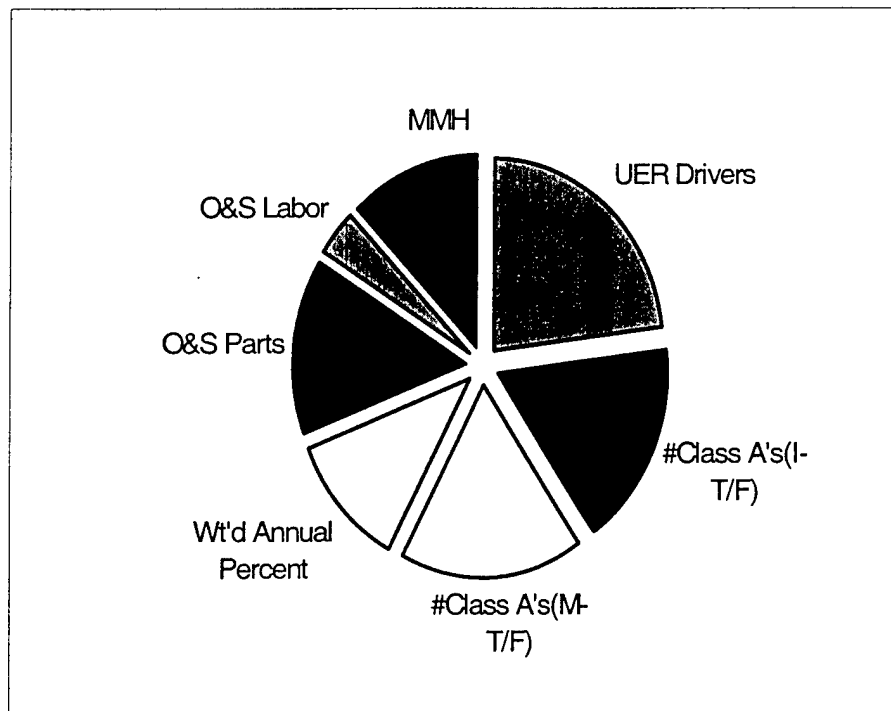

Figure 3.21 Global Weights of the Evaluation Measures

The impact of the some evaluation measures like UER drivers and number of Class A accidents are about the same. This research is expected to be weight sensitive depending on the global weights of the evaluation measures. Sensitivity analysis of the research will be presented in Chapter 4.

3.9 Modeling Assumptions

The F-16 Capability Enhancement Model is a new step toward a systematic approach of selecting engine modifications for the aircraft. There is no background study. There are separate teams working on the different aspects of the problem. This study is a result of a small team of individuals. The goal is to provide a framework for comparing modifications.

The hierarchy is built as a full model to help future researchers. However, the study is limited to the engine modifications due to time and data constraints. Using engine modifications for checking the model accuracy is adequate to validate the model.

It is assumed that engine modifications will not have a big impact on the combat score. The combat score sub-objective is weighted zero in the model. Another reason for zero weighting the combat score is lack of data. Data availability is the main driver in this study.

The alternatives used in the study are assumed to represent a typical sample of the F-16 modifications. Ten alternatives are selected for analyses in Chapter 4. The F-16 SPO identified the alternatives to test the model robustness.

The data for the alternatives are assumed to be independent, applying modification A does not change the result from applying modification B. The data for combat capability, safety, and operations costs are also assumed to be independent for a specific modification. A simple example helps clarify the issue. If a new type of air-to-air weapon is installed on the F-16, independence assumes that the vibration created by this weapon does not affect engine stalls or operations costs of the engine for future developments.

Some of the assumptions in this study should be relaxed in the future studies. Relaxing the assumptions depends on the available data rather than the decision analysis process.

3.10 Methodology Summary

In this chapter, reasons for selecting the VFT approach were discussed. Next, the modeling problems and solutions were introduced. The final model and definitions of the values were explained. Checking the model independence for using the additive value functions was explained. Determining the weights of the evaluation measure was discussed with an example. Finally modeling assumptions were highlighted to complete the chapter.

Chapter 4: Results and Analysis

4.1 Introduction

The F-16 Capability Enhancement Model is divided into two parts to help explain the analysis. The first part is the decision weights assigned by the decision-maker. The second part is the sub-model. Figure 4.1 shows these parts.

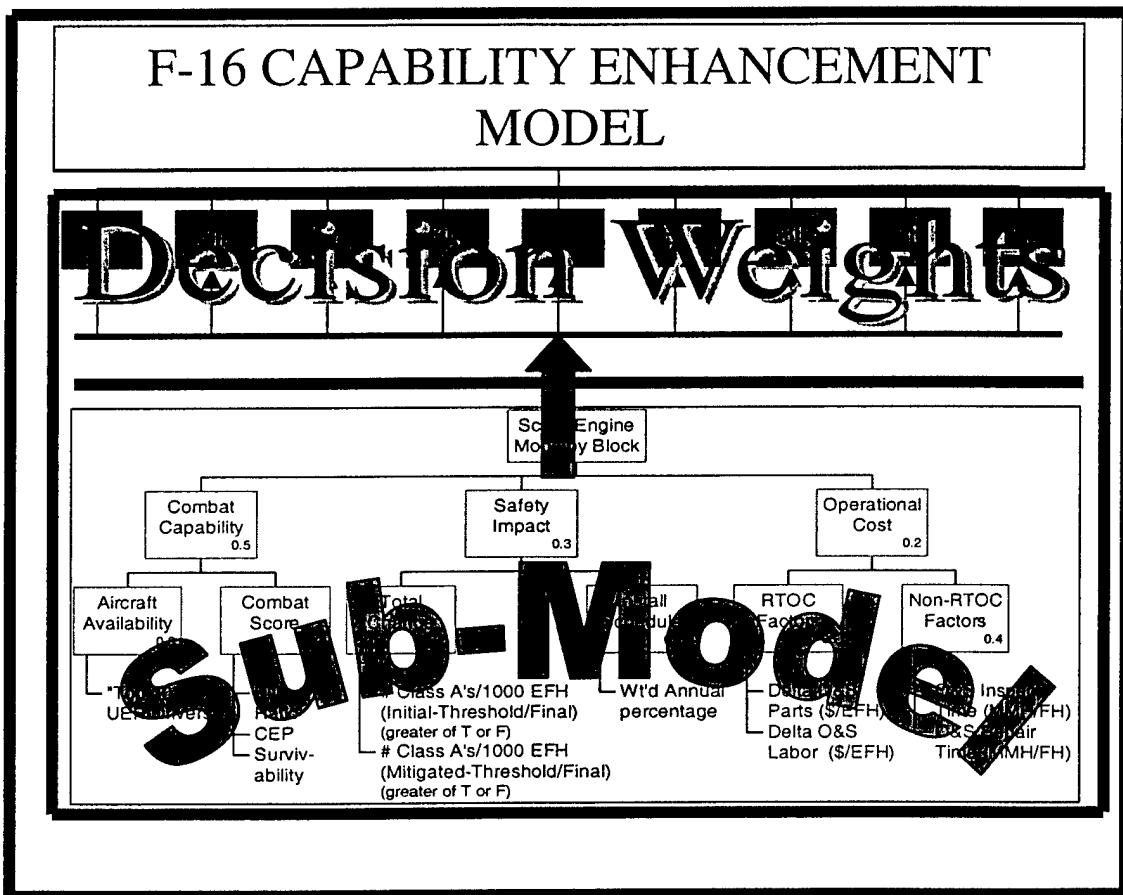

Figure 4.1 The F-16 Capability Model Parts

The analysis was performed after the value model for F-16 modification process was developed. First, the F-16 Capability Enhancement model is applied. This allows ranking of modifications. Three different rankings are performed due to the decision-maker's preferences in this part. The first ranking is based on the importance of the mission type and war capabilities of the fighter. The second is based on the fleet size of the aircraft. The last ranking is for the *Pratt Whitney Company (PW)*, who is one of the biggest engine providers for the USAF. Cost analysis is performed to quantify the benefit per dollar. For each modification, the rankings for mission type and fleet size are repeated to see the changes due to costs.

Second, a benefit/cost ratio greedy algorithm is applied to get insights from the benefit/cost ratios. In this algorithm, we simply take as many items as possible without exceeding our budget constraint, beginning with the biggest benefit/cost ratio. The result is not guaranteed to be optimal. Optimization techniques are applied to maximize the benefit of the modifications to the F-16 aircraft. This part maximizes the value of modifications while using the budget as a constraint. Integer programming is used to find an effective portfolio. Integer programming techniques may result in an optimized portfolio for a small problem. However, an optimized portfolio is not guaranteed for a large-scale decision-making model with many alternatives due to the limitations of integer programming. The limitations of integer programming are beyond the scope of this research. A detailed discussion about integer programming and its limitations can be found in Winston's book (Winston, 1994).

Finally, what if and sensitivity analysis are performed for the sub-model to see how stable the value model is with changes in weights. These analyses did not take the decision weights (upper tier in the model) into consideration since they are defined by the preferences of the F-16 Capability Enhancement Model users.

4.2 Model Application and Ranking the Alternatives

The F-16 Capability Enhancement Model is used to analyze the benefit to the F-16 aircraft of ten modifications currently in progress or planned in near future. However, there are 12 alternatives for the sub-model when the modifications' data are separated for different blocks. The data section of Figure 3.5 explains the data modification process.

4.2.1 The F-16 Capability Enhancement Model Ranking for Mission Type and War Capabilities

The decision weights in this section are assigned to blocks depending on their war capabilities in this part of the study. The F-16 Block 40/42 and 50/52 aircraft are valuable for the USAF in wartime. Aircraft blocks 10/15/25/30/32 had 0 decision weights since these aircraft are used for purposes like training, testing, and etc. Table 4.1, shown below, represents the decision weights of the aircraft blocks.

Table 4.1 Decision Weights

Aircraft Blocks	10	15	25	30	32	40	42	50	52	Total
Weights	0	0	0	0	0	0.1	0.1	0.4	0.4	1

Block 50/52 aircraft are heavily weighted because of their unique mission capabilities of suppression of enemy air defense (SEAD). These weights may vary due to the changing requirements of the decision-maker, but are assumed constant for this analysis. The weights in Table 4.1 are used to show the efficiency and flexibility of the model. The alternatives are ranked after the decision weights discussion. Table 4.2 shows the final rankings for the F-16 Capability Enhancement Model as defined in Figure 4.1.

Table 4.2 Ranking for Mission Type and War Capabilities

Engine Types	Alternatives	Blocks	Benefits
GE 129	Laser Shock Peen	50	0.1354
GE 129	Turbine Frame Outer Liner	50	0.0767
PW 229	2nd Fan Stator	52	0.0753
PW 229	#4 Bearing Seals	52	0.0746
PW 229	Oil Filter Housing	52	0.0744
PW 229	2nd Turbine Blade	52	0.0447
PW 229	Fuel Nozzle Damping	52	0.0331
GE 100	Ejector Nozzle	30-40	0.0217
GE 100	DEC Upgrade	30-40	0.0211
PW 229	Rear Fan Duct Patch	52	0.0065

The *GE 129 Laser Shock Peen* modification provides the most benefit to the F-16 aircraft as determined by the model. This is due to its being used in block 50 aircraft. The status quo case was not used for this study, since all the modifications analyzed have a potential of making a contribution to the F-16 capabilities. Instead, hypothetical best and worst cases were created to see the areas for development of the alternatives. Hypothetical worst and best cases' scores for evaluation measures are defined by using the best and worst scores of all alternatives under each evaluation measure. Therefore, it

is not expected that the best case scores, 1, and worst case scores, 0, for all objectives due to the range of the evaluation measures. The evaluation measure ranges were defined depending on the requirements of the decision-maker as explained in Chapter 3. Table 4.3, shown below, demonstrates a simple example.

Table 4.3 An example for Hypothetical Best and Worst Cases

	Objective 1 Global Weight=0.33		Objective 2 Global Weight=0.33		Objective 3 Global Weight=0.33		Total Value
	Score	Value	Score	Value	Score	Value	
Range	0-10	0-1	0-100	0-1	0-1	0-1	
Alternative 1	8	0.8	50	0.50	0.4	0.4	0.56
Alternative 2	6	0.6	25	0.25	0.7	0.7	0.51
Alternative 3	2	0.2	85	0.85	0.1	0.1	0.38
Best Case	8	0.8	85	0.85	0.7	0.7	0.78
Worst Case	2	0.2	25	0.25	0.1	0.1	0.18

The decision-maker defines ranges for evaluation measures in this example. Single dimensional value functions are assumed to be piecewise linear functions. The best case takes the scores from alternative 1 in objective 1, alternative 3 in objective 2, and alternative 2 in objective 3. This results in a total value of 0.78 assuming equal global weights for each objective. Similarly, worst case takes the scores from alternative 3 in objective 1, alternative 2 in objective 2, and alternative 3 in objective 3. This results in a total value of 0.18. Thus, this example shows that the value of best case may not be equal to 1 and the value of worst case may not be equal to 0.

Figure 4.2, shown below, represents the contribution of each objective for the modifications specific to the block type in the sub-model. The ranking in Figure 4.2 does not take the decision weights into consideration because the decision weights are defined

as the changing preferences of the decision-maker. The goal is to show the modifications' achievement level in the sub-model. There are 12 modifications that are scored in the sub-model. Figure 3.5 in Chapter 3 explains the data process.

Ranking for Best Eng. Mods Goal

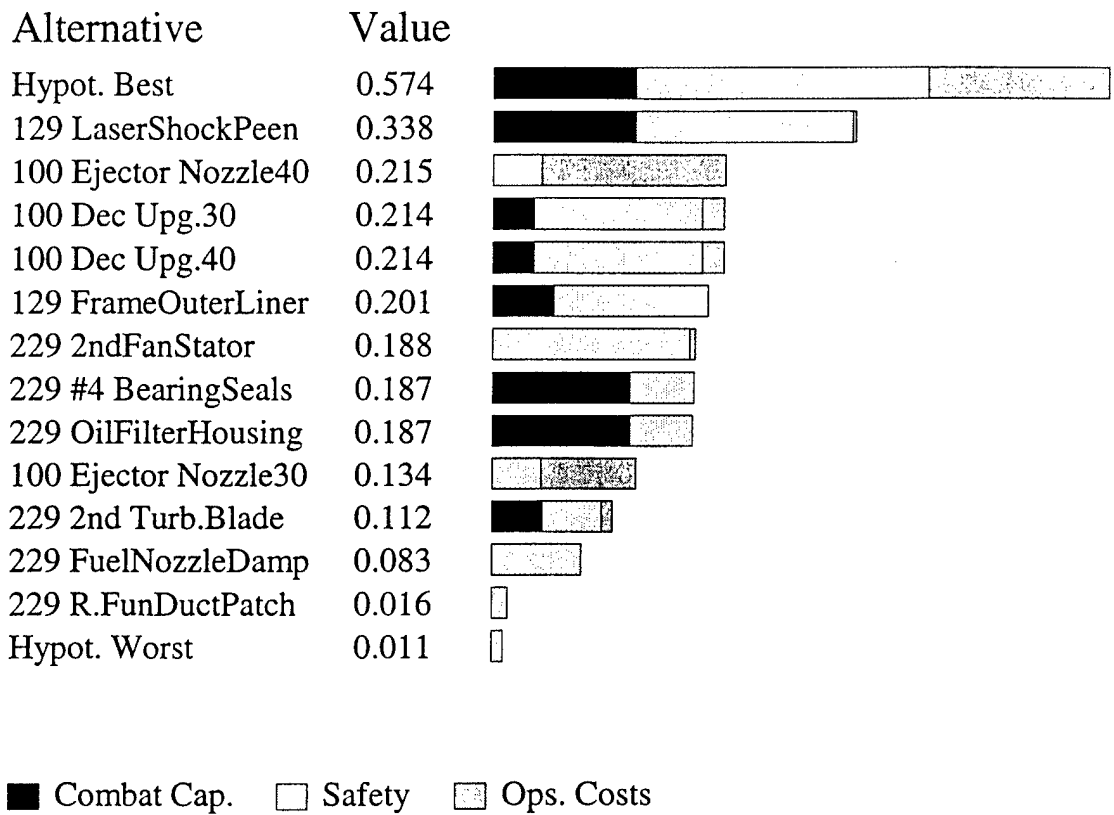

Preference Set = F-16 Capability Enhancement Model

Figure 4.2 Fundamental Objectives' Contributions

The hypothetical best case gets a value of 0.574. The closest modification to hypothetical best case is *GE 129 Laser Shock Peen*. Improving the combat capability of the aircraft is

the most important ability of this modification. Contribution to safety is another aspect of the modification and is considered significant by the decision-maker. However, the operations cost of the modification is highly expensive. The cost must be improved (decreased) for better results. The second modification in the ranking is *GE 100 Ejector Nozzle (Block 40)*. This modification is a safety modification and it does not have any contribution to the F-16 combat capability. The other GE engine modifications score close to each other. The only exception is the *GE 100 Ejector Nozzle (Block 30)*. The operations cost of the engines depends on the remaining fleet life. The remaining fleet life for the block 40 engines are longer than block 30 engines. Thus, the *GE 100 Ejector Nozzle (Block 30)* modification scores weakly when it is compared to the *GE 100 Ejector Nozzle (Block 40)* modification due to its high operations costs. *PW 229 2nd Fan Stator, #4 Bearing Seals and Oil Filter Housing* are the first modifications in the list for PW 229 engine. The *2nd Fan Stator* is a safety modification and does not contribute to the combat capability objective. The last two modifications for PW 229 (*Fuel Nozzle Damp and Rear Fun Duct Patch*) score very low and the implementation of these modifications should not be considered as improving the aircraft capabilities. The overall result is that the GE engine modifications are achieving better results than PW engine modifications in the sub-model.

The sub-model's combat capability, safety, and operational costs' individual rankings can also be shown. The Figure 4.3 shows the sub-model's ranking for the combat capability objective. However, the ranking was done only for aircraft availability since the combat score was weighted 0 in the model. Note that the decision weights (top tier) are not used in the ranking for combat capability, safety, and operations costs, since

they depend on the preferences of the decision-maker. The goal of Figure 4.3 is to show the weak and strong properties of the modifications used in the sub-model and provide better insights for the decision-maker.

Ranking for Combat Cap. Goal

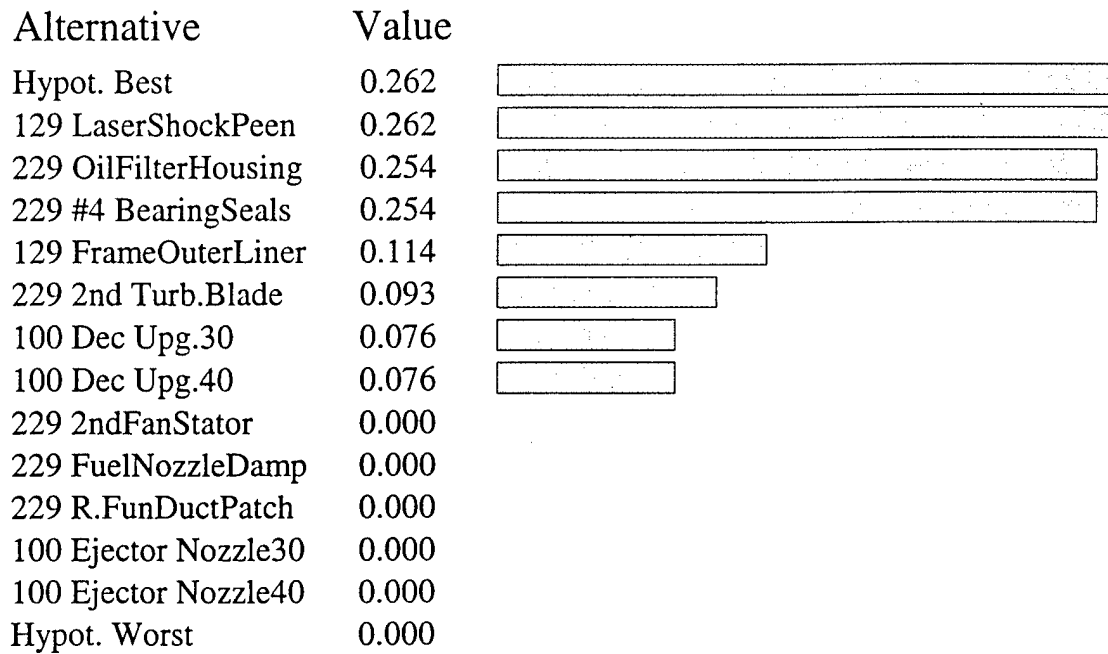

■ Combat Score □ A/C Avail.

Preference Set = F-16 Capability Enhancement Model

Figure 4.3 Ranking for Combat Capability

The Logical Decisions software was used for this part of the study. If the analyst wants to rank the alternatives depending on an objective, the software sets the global weight of

that objective to 1. However, the weight ratios defined by the decision-maker stay the same. The global weights were adjusted to 0.7 and 0.3 for combat capability and aircraft availability in this section. The global weight for combat capability is set to 0 as discussed earlier. Therefore, the only criterion in this portion of the model is availability. The UER driver evaluation measure score (only evaluation measure for sub-objective A/C availability) for hypothetical best case is the same score as *GE 129 Laser Shock Peen* modification. The *PW 229 Oil Filter Housing and #4 Bearing Seals*' values are very close to the hypothetical best case. It can be stated that there is minimal difference between the impacts of *GE 129 Laser Shock Peen*, *PW 229 Oil Filter Housing and #4 Bearing Seals* on the aircraft availability. However, the values following these modifications decrease dramatically. The other important insight is that if aircraft availability is an important issue, the ranking for *GE 100 DEC Upgrade (Block 30/40)* changes severely due to its decreasing value in the sub-model. The last 5 modifications on the list (*PW 229 2nd Fan Stator*, *PW 229 Fuel Nozzle Dump*, *PW 229 Rear Fun Duct Pacht*, and *GE 100 Ejector Nozzle Block 30/Block 40*) do not impact aircraft availability at all. The decision-maker has to keep in mind that combat capability is the most important part of this model, considering its global weight. Improving the performances of the modifications for aircraft availability changes the overall values significantly.

The total change in class A mishap rate and installation schedule are the sub-objectives of the safety. The sub-model's ranking for *Safety* is shown in Figure 4.4 below. Safety is an important concern in the study since the human life cannot be replaced. The decision weights are not considered in the ranking.

Ranking for Safety Goal

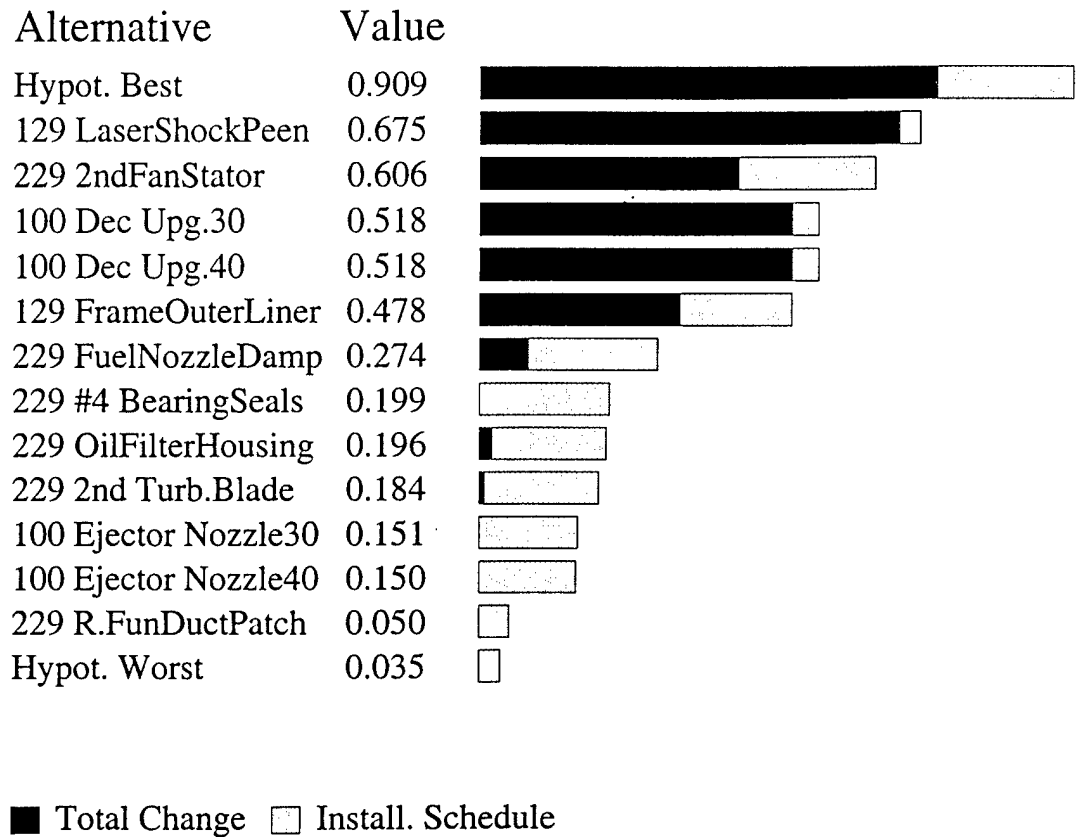

Preference Set = F-16 Capability Enhancement Model

Figure 4.4 Ranking for Safety

The hypothetical best case score is 0.909 for the safety objective. The *GE 129 Laser Shock Peen* has the closest value to the hypothetical best case. This modification scores high under total change in class A mishap rates sub-objectives. However, the installation schedule of this modification has to be improved for better results. The *PW 229 2nd Fan Stator* is the second modification on the list (excluding the hypothetical best case). The

installation schedule score for this modification is the best one under installation schedule sub-objective (WAPM value). Increasing the safety capability of this modification will increase modification score. However, this might not be possible for technical reasons. The *GE 100 DEC Upgrades (Block 30/40)* are next on the list. The installation schedule for these modifications must be improved to increase the values of these modifications. The *GE 129 Frame Outer Liner and PW 229 Fuel Nozzle Damp* are next in the ranking. The last 5 modifications on the list (*PW 229 #4 Bearing Seals, PW 229 Oil Filter Housing, PW 229 2nd Turbine Blade, GE 100 Ejector Nozzle Block 30/Block 40*) do not contribute to the objective of reducing class A mishap rates for the F-16. They score average under the installation schedule sub-objective. The *PW 229 Rear Fun Duct Patch* is the final modification on the ranking. If class A mishap rates become a bigger concern, these last 6 modification do not have to be considered as valuable modifications. Improving the installation schedule for *GE 129 Laser Shock Peen, and GE 100 DEC Upgrades (Block 30/40)* increase the values of these modifications considerably.

Operations cost is divided into two sub-objectives, RTOC factors and non-RTOC factors. Figure 4.5, shown below, shows the sub-model's ranking for operational costs. The decision weights are not used in the ranking as explained previously.

Here the hypothetical best case gets a value of 0.852. The hypothetical best case gets its score mostly from *GE 100 Ejector Nozzle (Block 40)* modifications. This modification is considered the first one to be implemented if the operations costs were the most important issue in the problem.

Ranking for Ops. Costs Goal

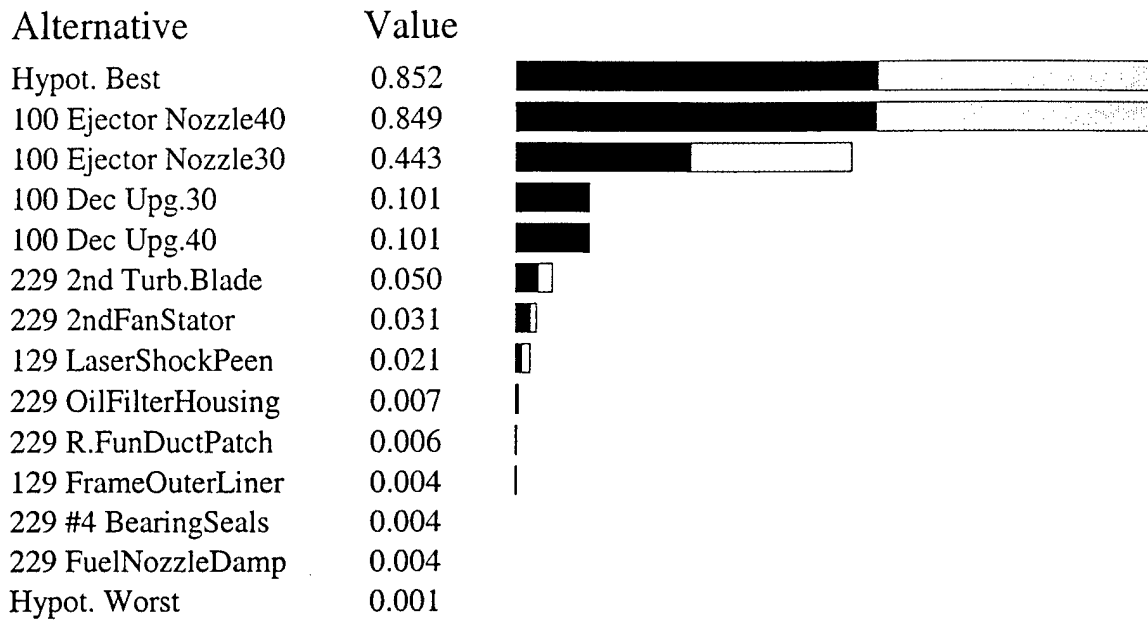

■ RTOC □ non-RTOC

Preference Set = F-16 Capability Enhancement Model

Figure 4.5 Ranking for Operations Cost

The GE 100 Ejector Nozzle (Block 30) is the 2nd modification in the list. The blocks score differently depending on their costs data and this data depend on the remaining fleet life as explained previously (RTOC and non-RTOC values). The remaining modifications on the lists score very low. The GE 129 Laser Shock Peen and PW 229 2nd Fan Stator are important modifications for combat capability and safety. However, they score disappointingly under operations costs. These low scoring under operations costs

may impair their overall contributions. Improving their cost scores may help these modifications to become clear winners for sub-model. The last 5 modifications do not have to be considered if the costs factors are driving the decision-maker. After reviewing these figures, the most important insights for the decision-maker are:

- The installation schedule scores for GE 100/129 engines must be improved.
- The operations costs of PW 229 and GE 129 engine modifications must be decreased. If the operations cost is a real concern, GE 100 modifications have to be considered as the most valuable ones.

Figures 4.3, 4.4, and 4.5 present a big picture of the achievements of alternatives for the objectives (1st tier). The contribution for each evaluation measure in the sub-model can also be shown to see how well the modifications achieve these metrics. Figure 4.6 shows the contributions for each evaluation measure for F-16 Capability Enhancement Model. There are 10 evaluations measures in the model. Kill ratio, CEP, and survivability evaluation measures did not have any contribution to the overall values since they are weighted 0 in the model. Figure 4.6, shown below, is a more detailed look for all the modifications used in this study.

The *GE 129 Laser Shock Peen* is the most effective modification in the list. It was explained before the operations costs and installation schedule of this alternative must be improved for better results. Figure 4.6 shows areas for improvement for each modification. Improving the scores for O&S parts, WAPM, or the MMH cost for *GE 129 Laser Shock Peen* improve its overall value dramatically depending on the global weight of the evaluation measures.

Ranking for Best Eng. Mods Goal

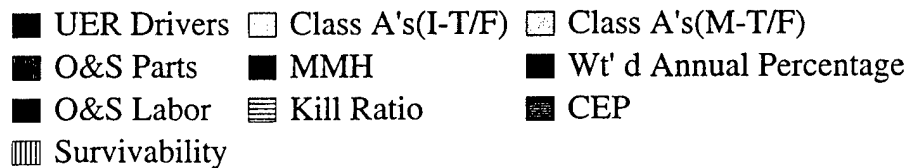
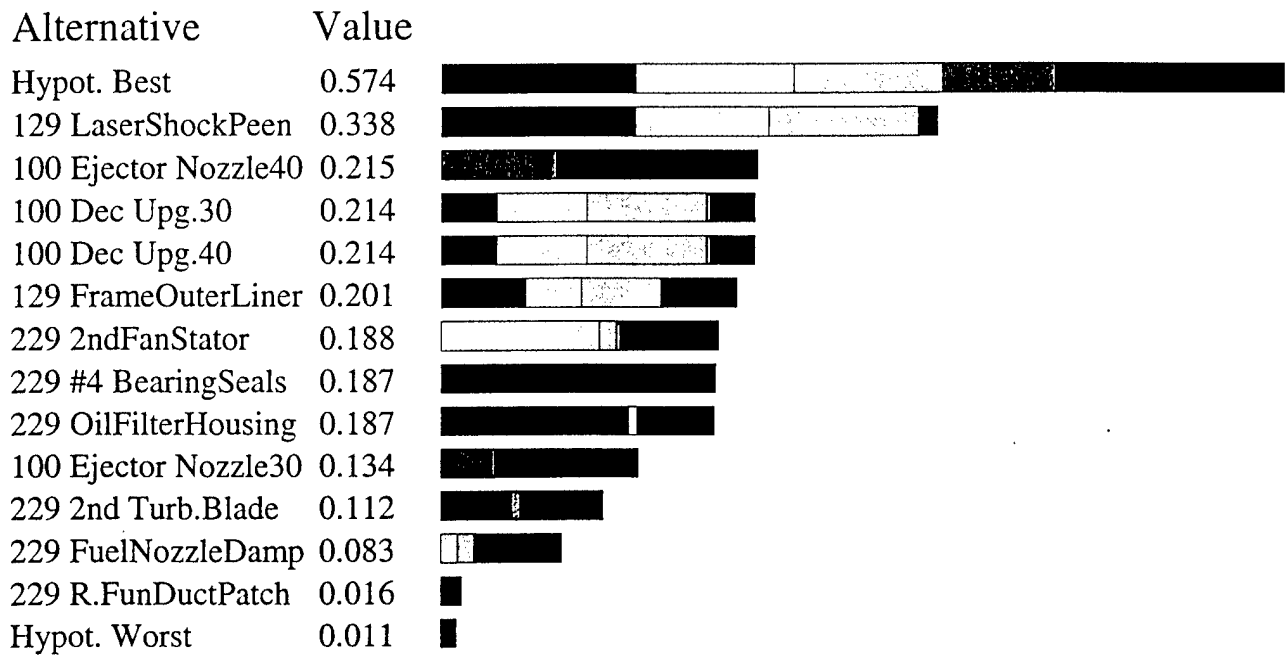

Preference Set = F-16 Capability Enhancement Model

Figure 4.6 Evaluation Measures' Contributions

The *GE 100 Ejector Nozzle (Block 40)* is the second modification on the list. However, the decision-maker has to be careful at this point. The overall value for this modification is mostly originated from operations costs. Considering this result, this modification may not be an effective option for F-16 Capability Enhancement. The *GE*

100 DEC Upgrade (Block 30/40) and GE 129 Frame Outer Liner values are very close to each other. O&S parts, WAPM, or the cost for MMH are the areas that may be enhanced for these modifications. However, the *GE 129 Frame Outer Liner's* score for O&S Labor can improve the modification ranking. The first PW 229 modification in the ranking is the *PW 229 2nd Fan Stator*. The values for *PW 229 2nd Fan Stator*, *PW 229 #4 Bearing Seals*, and *PW 229* are very close. Therefore, improving scores for different areas (score for O&S Labor, O&S parts, or the cost for MMH) may change the ranking noticeably. The next modification is the *GE 100 Ejector Nozzle (Block 30)* which scores extremely low when compared to *GE 100 Ejector Nozzle (Block 40)*. The remaining modifications are not valuable for the F-16 aircraft based on the values of the decision-maker.

4.2.2 The F-16 Capability Enhancement Model Ranking for Fleet Size

Normalization for fleet size is used to find decision weights. The total aircraft number is used for the normalization value. The number of specific block aircraft is divided by the total number of aircraft to get the normalization figures. Table 4.4 summarizes the process to find the normalized values.

Table 4.4 Normalization for Aircraft Number

Blk	Qty	Blk Total	Normalized Values
10A	15	35	35/1436
10B	20		0.024
15A	88	109	109/1436
15B	21		0.076
25C	180	212	212/1436
25D	32		0.148
30C	324	366	366/1436
30D	42		0.255
32C	49	53	53/1436
32D	4		0.037
40C	213	240	240/1436
40D	27		0.167
42C	140	186	186/1436
42D	46		0.130
50C	154	181	181/1436
50D	27		0.126
52C	42	54	54/1436
52D	12		0.038
Total		1436	

Table 4.5 shows the decision weights used in this section of the analysis.

Table 4.5 Decision Weights for Fleet Size

Aircraft Blocks	10	15	25	30	32	40	42	50	52	Total
Weights	0.024	0.076	0.148	0.255	0.037	0.167	0.130	0.126	0.038	1

Table 4.6 shows the F-16 Capability Enhancement Model's ranking. The *Digital engine component (DEC) upgrade for GE 100 engine* is the winning alternative. This was expected, since the block 30 aircraft comprise the largest portion of the USAF fleet.

Table 4.6 Ranking for Fleet Size

Engine Types	Alternatives	Blocks	Benefits
GE 100	DEC Upgrade	30-40	0.08912
GE 100	Ejector Nozzle	30-40	0.07061
GE 129	Laser Shock Peen	50	0.04266
GE 129	Turbine Frame Outer Liner	50	0.02418
PW 229	2nd Fan Stator	52	0.00708
PW 229	#4 Bearing Seals	52	0.00701
PW 229	Oil Filter Housing	52	0.00700
PW 229	2nd Turbine Blade	52	0.00420
PW 229	Fuel Nozzle Damping	52	0.00312
PW 229	Rear Fan Duct Patch	52	0.00061

The GE 100/129 engine modifications receive higher values than PW 229 engine modifications. This is predictable since they form the largest percentage of USAF fleet.

The most important PW 229 modification appears to be the *PW 229 2nd Fan Stator*.

However, *PW 229 #4 Bearing Seals and PW 229 Oil Filter Housing's* values are close to the value of *PW 229 2nd Fan Stator*. The subsequent modifications on the list do not have big impacts on the enhancement of F-16 capabilities when normalized by fleet size.

The graphs for sub-model's combat capability, safety, and operational cost contributions are the same with mission type and war capabilities' graphs since the only changing data are the decision weights for F-16 Capability Enhancement Model. The decision weights do not impact the sub-model performance of the modifications. Sub-model is based on the data, while the top tier changes the overall rankings due to the decision-maker's preferences. As seen in Table 4.5, the rankings can change dramatically.

4.2.3 The F-16 Capability Enhancement Model Ranking for Pratt Whitney Engines

Many decision-maker questions can be answered because of the flexibility of the decision weights in the F-16 Capability Enhancement Model. One important question was ranking the alternatives for different manufacturers. Table 4.7 shows the F-16 Capability Enhancement Model ranking for PW engines. Block 10/15/25/32/42/52 aircraft use the PW engines. Thus, the decision weights were equally distributed. Each block type had a decision weight of 0.166 (The total decision weight = 1, PW blocks = 6). This simple case is used to show the broad capabilities of the model. However, different decision weights may be built depending on the preferences of the decision-maker. Fleet size of PW engines or the war capabilities of different PW engines may result in different decision weights sets. However, this simple case demonstrates the flexibility and tries to keep away of the interaction issues that may be a result of changing preferences of the decision-maker.

Table 4.7 Ranking for PW Engines

Engine Types	Alternatives	Blocks	Benefits
PW 229	2nd Fan Stator	52	0.03136
PW 229	#4 Bearing Seals	52	0.03108
PW 229	Oil Filter Housing	52	0.03101
PW 229	2nd Turbine Blade	52	0.01860
PW 229	Fuel Nozzle Damping	52	0.01381
PW 229	Rear Fan Duct Patch	52	0.00271

The 2nd Fan Stator for PW 229 is the 1st alternative. However, the values for PW 229 #4 Bearing Seals and PW 229 Oil Filter Housing are very close. Therefore, it can be stated

that there is minimal difference among the impacts of these 3 alternatives. The final modification, *PW 229 Rear Fun Duct Patch* does not contribute significantly to the F-16 capabilities. The graphs for sub-model's combat capability, safety, and operational cost contributions are the same with mission type and war capabilities' graphs as explained previously.

4.3 The Cost of Enhancing the F-16 Capabilities

It is not completely true to conclude that the F-16 organizations should only fund the alternatives resulting in the greatest benefit to the F-16. The benefit comes at a price. A value analysis approach is useful for cost analysis because it provides a systematic method that allows everyone involved in the capital budgeting process to provide information in a clear and mutually understood way (Kirkwood, 1997:200-206). Benefit/cost ratio analysis is used for this part of study. It is a widely used method for analyzing resource allocation decisions. The best modifications are defined as the ones providing big change in benefits at the smallest possible cost. The acquisition cost in this part of analysis is defined as the cost of a modification for a single engine. Table 4.8 and Table 4.9 show the re-ranked modifications for the F-16 Capability Enhancement Model from highest to lowest benefit/cost ratio depending on the decision weights for *Mission Type and War Capability* and *Fleet Size*.

Table 4.8 Benefit/Cost Ratio Ranking for Mission Type and War Capability

Engine Types	Alternatives	Blocks	Benefit	Benefit/Cost
GE 129	Turbine Frame Outer Liner	50	0.0767	0.00029854
PW 229	#4 Bearing Seals	52	0.0746	0.00011782
PW 229	Oil Filter Housing	52	0.0744	0.00002961
PW 229	Rear Fan Duct Patch	52	0.0065	0.00001836
GE 129	Laser Shock Peen	50	0.1354	0.00000952
PW 229	Fuel Nozzle Damping	52	0.0331	0.00000390
PW 229	2nd Fan Stator	52	0.0753	0.00000384
PW 229	2nd Turbine Blade	52	0.0447	0.00000112
GE 100	Ejector Nozzle	30-40	0.0217	0.00000017
GE 100	DEC Upgrade	30-40	0.0211	0.00000012

The *Turbine Frame Outer Liner* for *GE 129* engine is the winning modification. The *PW 229 #4 Bearing Seals* and *PW 229 Oil Filter Housing* are the next modifications on the list. The *GE 129 Laser Shock Peen* is fifth due to its expensive acquisition cost. This position is a striking change when compared to Table 4.2. The *2nd Fan Stator* for *PW 229*, *Digital engine component (DEC) upgrade* for *GE 100* are other modifications impaired by their high acquisition expenses. As in Table 4.7, the ranking changes considerably when the acquisition costs are taken into consideration.

Table 4.9 Benefit/Cost Ratio Ranking for Fleet Size

Engine Types	Alternatives	Blocks	Benefits	Benefit/Cost
GE 129	Turbine Frame Outer Liner	50	0.02418	0.00009407
PW 229	#4 Bearing Seals	52	0.00701	0.00001108
GE 100	Ejector Nozzle	30-40	0.07061	0.00000543
GE 100	DEC Upgrade	30-40	0.08912	0.00000522
GE 129	Laser Shock Peen	50	0.04266	0.00000300
PW 229	Oil Filter Housing	52	0.00700	0.00000278
PW 229	Rear Fan Duct Patch	52	0.00061	0.00000173
PW 229	Fuel Nozzle Damping	52	0.00312	0.00000037
PW 229	2nd Fan Stator	52	0.00708	0.00000036
PW 229	2nd Turbine Blade	52	0.00420	0.00000011

The *Turbine Frame Outer Liner for GE 129* engine is the winning modification for this ranking as well. The benefit/cost ratios decrease significantly in the table. The *PW 229 #4 Bearing Seals* is the next essential modification on the list. The *GE 100 DEC Upgrade* does not have an important ranking position owing to its high acquisition expenses when it is compared to Table 4.6. Table 4.10, shown below, represents the benefit/cost ratio ranking for PW engines.

Table 4.10 Benefit/Cost Ratio Ranking for PW Engines

Engine Types	Alternatives	Blocks	Benefits	Benefit/Cost
PW 229	#4 Bearing Seals	52	0.03108	0.0000491
PW 229	Oil Filter Housing	52	0.03101	0.0000123
PW 229	Rear Fan Duct Patch	52	0.00271	0.0000076
PW 229	Fuel Nozzle Damping	52	0.01381	0.0000016
PW 229	2nd Fan Stator	52	0.03136	0.0000016
PW 229	2nd Turbine Blade	52	0.01860	0.0000005

The *#4 Bearing Seals for PW 229* is highest alternative per dollar invested. The *PW 229 Oil Filter Housing* ranks in the second position. The first striking change in the rankings is the new place of *PW 229 Rear Duct Fan Patch*. This modification ranks higher due to its lower acquisition expenses. The other important ranking change is the position of *PW 229 2nd Fan Stator* when acquisition cost is important. The modification suffers due to its high acquisition costs.

Benefit/cost ratio greedy algorithm is applied to find a set or portfolio of best modifications. In this step, it is assumed that the value and cost of a modification does not change when it was combined with other modifications. Therefore, it is possible to

sum the benefits and costs to build a set of best alternatives (Kirkwood, 1997:203). Table 4.11 shows the results for *Mission Type and War Capabilities*. The total cost for the modification (acquisition cost for an engine times the number of aircraft modified by a specific modification) is used to give better insights about the most effective budgeting policy for the F-16 organizations. The costs are expressed in thousands of dollars.

Table 4.11 Greedy Algorithm Results for Mission Type and War Capabilities

Engine Types	Alternatives	Costs					
		Blocks	Benefit (thousand)	Benefit/Costs	CUM Ben.	CUM costs	
PW 229	#4 Bearing Seals	52	0.0746	48.7	0.00153143	0.07458	48.7
GE 129	Turbine Frame Outer Liner	50	0.0767	77.9	0.00098493	0.15131	126.6
PW 229	Oil Filter Housing	52	0.0744	193.5	0.00038460	0.22573	320.1
PW 229	Rear Fan Duct Patch	52	0.0065	27.3	0.00023807	0.23223	347.4
PW 229	Fuel Nozzle Damping	52	0.0331	654.5	0.00005064	0.26537	1001.9
PW 229	2nd Fan Stator	52	0.0753	1509.2	0.00004987	0.34063	2511.1
GE 129	Laser Shock Peen	50	0.1354	4310.2	0.00003141	0.47602	6821.3
PW 229	2nd Turbine Blade	52	0.0447	3064.7	0.00001457	0.52067	9886.0
GE 100	Ejector Nozzle	30-40	0.0217	103740.0	0.00000021	0.54237	113626.0
GE 100	DEC Upgrade	30-40	0.0211	136218.6	0.00000016	0.56350	249844.6

The *PW 229 #4 Bearing Seals* is the first on the list. However, the decision-maker must be careful while considering the ranking in the list. The rankings mainly depend on the total number of aircraft modified. Therefore, this analysis tries to enlighten the budgeting profile question of the ASC without providing an optimal solution. The *GE 129 Turbine Frame Outer Liner* is the 2nd ranked modification. The modifications *GE 100 Ejector Nozzle (Block30/40)*, *GE 129 Laser Shock Peen*, and *PW 229 2nd Fan Stator* are not achieving successful results because of their total costs. Graph

shown in Figure 4.7 explains the relationship between cumulative cost and cumulative benefit. The costs are expressed in thousands of dollars.

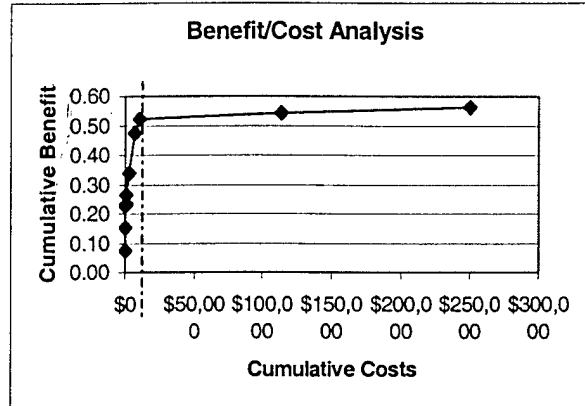

Figure 4.7 Plot of Cumulative cost versus Cumulative Benefit for Mission Type and War Capabilities

This graph shows that the first hundred thousand dollars buy substantial benefits. There is not much additional benefit for the last few modifications considering their excessive costs. For the first 8 modifications, the graph has an increasing steep line showing that cumulative benefit increase dramatically for these modifications. ASC may get a total value of 0.5 while spending less than 10 million dollars. The last two GE 100 engine modifications propose a very low value increment for a big price change. These modifications may be left out of an effective modification set without impacting the very high value for the objective function.

Table 4.12, shown below, demonstrates the results for *Fleet Size*. The costs are expressed in thousands of dollars.

Table 4.12 Greedy Algorithm Results for Fleet Size

Engine Types	Alternatives	Blocks	Benefits	Costs (thousand)	Benefit/Costs	CUM Ben	CUM costs
GE 129	Turbine Frame Outer Liner	50	0.02418	77.9	0.00031036	0.02418	77.9
PW 229	#4 Bearing Seals	52	0.00701	48.7	0.00014397	0.03119	126.6
PW 229	Oil Filter Housing	52	0.00700	193.5	0.00003616	0.03819	320.1
PW 229	Rear Fan Duct Patch	52	0.00061	27.3	0.00002238	0.03880	347.4
GE 129	Laser Shock Peen	50	0.04266	4310.2	0.00000990	0.08146	4657.6
PW 229	Fuel Nozzle Damping	52	0.00312	654.5	0.00000476	0.08458	5312.1
PW 229	2nd Fan Stator	52	0.00708	1509.2	0.00000469	0.09165	6821.3
PW 229	2nd Turbine Blade	52	0.00420	3064.7	0.00000137	0.09585	9886.0
GE 100	Ejector Nozzle	30-40	0.07061	103740.0	0.00000068	0.16646	113626.0
GE 100	DEC Upgrade	30-40	0.08912	136218.6	0.00000065	0.25558	249844.6

The *GE 129 Turbine Frame Outer Liner* is ranked first. *GE 100 engine* modifications are the final 2 modifications in the list due to their total costs. The *GE 129 Laser Shock Peen* and *PW 229 2nd Fan Stator* are valuable modifications, however, their values are impaired by the total costs. It is important to understand that this ranking is not the only consideration to pick the most beneficiary modifications. Table 4.12 provides insight about an effective modification set. Figure 4.8 shows the relationships between cumulative cost and cumulative benefit. The costs are expressed in thousands of dollars.

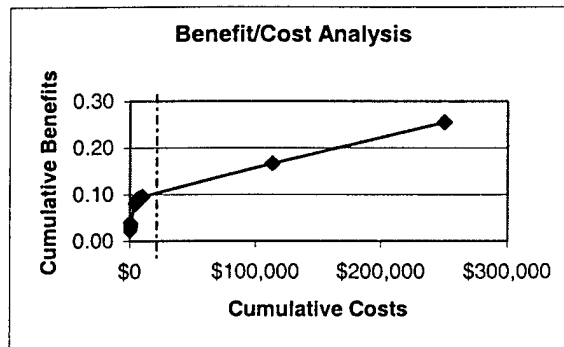

Figure 4.8 Plot of Cumulative Cost versus Cumulative Benefit for Fleet Size

The graph shows that the dollars invested in the project buy substantial benefit for the aircraft. Decrease in the value shows that changing decision weights for fleet size results in poor outcomes. However, if the budget increases, the cumulative benefits increase in larger amount due to the higher slope of the line (compared to Figure 4.8). The decision-maker would have to decide on the last 2 modifications depending on the budget of the organization.

The same analysis is used for PW engines. Table 4.13 summarizes the process.

The costs are expressed in thousands of dollars.

Table 4.13 Greedy Algorithm Results for PW Engines

Engine Types	Alternatives	Costs					
		Blocks	Benefits	(thousand)	Benefit/Costs	CUM Ben	CUM costs
PW 229	#4 Bearing Seals	52	0.03108	48.7	0.00063809	0.03108	48.7
PW 229	Oil Filter Housing	52	0.03101	193.5	0.00016025	0.06208	242.2
PW 229	Rear Fan Duct Patch	52	0.00271	27.3	0.00009919	0.06479	269.5
PW 229	Fuel Nozzle Damping	52	0.01381	654.5	0.00002110	0.07860	924
PW 229	2nd Fan Stator	52	0.03136	1509.2	0.00002078	0.10996	2433.2
PW 229	2nd Turbine Blade	52	0.01860	3064.7	0.00000607	0.12856	5497.9

The *PW 229 #4 Bearing Seals* is the first ranked modification due to its low total cost.

Figure 4.9 explains the relationships between the cumulative benefits and the costs for modifying PW engines. The costs are expressed in thousands of dollars.

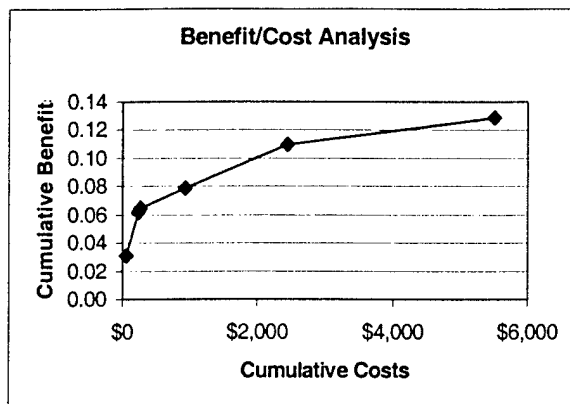

Figure 4.9 Plot of Cumulative Cost versus Cumulative Benefit for PW Engines

However, a more effective set may be formed by not applying *PW 229 Rear Fun Duct Patch*. This modification gives a very little benefit improvement for the aircraft. All PW engines may be modified for less than 5.5 million dollars due to the limited alternatives given for this research. This highlights the relatively inexpensive nature of PW engine modifications when compared to GE engine modifications.

Despite the fact that benefit/cost analysis is an applicable technique for portfolio selection models, the process has some limitations. Kirkwood explains these limitations in his book (Kirkwood, 1997). There are two important limitations that should be understood by the decision-maker. First, the selected portfolio is not necessarily optimal (Kirkwood, 1996: 200-205). Second, the method only uses a single budget constraint (cost) (Kirkwood, 1997: 206). Linear and integer programming techniques help with portfolio optimization in small decision problems. However, for big decision models with many alternatives, optimized portfolios are not guaranteed by linear or integer programming techniques.

4.4 Optimizing the Portfolio

For this part of the analysis, All-or-Nothing or Partial-Funding policies can be used. All-or-nothing policies are the case where a modification is either fully funded or dropped from the desired portfolio. Partial-funding allows a fraction of a modification to be funded. This study uses all or nothing funding policy. The following binary, or 0-1, math is used to determine the optimal portfolio solution for the all or nothing funding policy:

Let $x_i = 1$ if the modification "i" is funded and 0 if not funded

Let V_i = The value change (benefit) in the F-16 capabilities due to implementation of the modification i

Let C_i = The total cost of the modification i (total number of aircraft modified * acquisition cost for an engine)

Let B = Available budget for a portfolio of modifications

Let $i = 1..10$ (The alternatives or modifications for the analysis)

Maximize the total value = $\sum_i V_i * x_i$

Subject to

$$\sum_i C_i * x_i \leq B$$

where

$x_i = \{0,1\}$ for all i

The optimal portfolio for *fleet size* was found by using an all or nothing funding policy since this research is concerned about the overall fleet budget. The values for the benefit

(V_i) and the cost (C_i) are taken from the Table 4.11. The process for *mission type and war capabilities* and *PW engines* are the same. The only change is the figures for V_i due to the changing benefits of the modifications for different scenarios (mission type and war capability benefits and PW engine benefits) as explained and shown previously. The Excel Solver software was used for this part of the study. The modifications are coded with capital letters for the efficiency. Table 4.14 shows the coded modifications.

Table 4.14 Coded Modifications

Engine Types	Alternatives	Blocks	Benefits	Coded
GE 100	DEC Upgrade	30-40	0.08913	A
GE 100	Ejector Nozzle	30-40	0.07061	B
GE 129	Laser Shock Peen	50	0.04266	C
GE 129	Turbine Frame Outer Liner	50	0.02418	D
PW 229	2nd Fan Stator	52	0.00708	R
PW 229	#4 Bearing Seals	52	0.00701	F
PW 229	Oil Filter Housing	52	0.00700	G
PW 229	2nd Turbine Blade	52	0.00420	H
PW 229	Fuel Nozzle Damping	52	0.00312	I
PW 229	Rear Fan Duct Patch	52	0.00061	J

Table 4.15 shows the results from the F-16 Capability Enhancement Model with changing budgets. The objective function (OBJ. FUNC.) value is the total benefit of the selected portfolio given the budget constraint. Right hand side (RHS) value is the budget constraint in thousands dollars. The RHS is increased to reflect modification sets produced for different budget constraints. The USED column is the money in thousands of dollars spent for the specific portfolio. As indicated, the total cost of each modification set does not have to equal the budget. This represents slack in the budget constraint.

Table 4.15 Optimization for Fleet Size

OBJ. FUNC.	A	B	C	D	E	F	G	H	I	J	RHS	USED
0.01773	0	0	0	0	0	1	1	0	1	1	\$1,000.00	\$924.00
0.04587	0	0	0	1	1	1	1	0	0	1	\$2,000.00	\$1,856.57
0.04899	0	0	0	1	1	1	1	0	1	1	\$3,000.00	\$2,511.07
0.08146	0	0	1	1	0	1	1	0	0	1	\$5,000.00	\$4,657.55
0.09585	0	0	1	1	1	1	1	1	1	1	\$10,000.00	\$9,885.92
0.16646	0	1	1	1	1	1	1	1	1	1	\$120,000.00	\$113,625.90
0.18497	1	0	1	1	1	1	1	1	1	1	\$150,000.00	\$146,104.50
0.25558	1	1	1	1	1	1	1	1	1	1	\$250,000.00	\$249,844.50

Table 4.15 demonstrates the integer programming and effective sets produced. Figure 4.10 demonstrates the benefit versus costs of different modification sets.

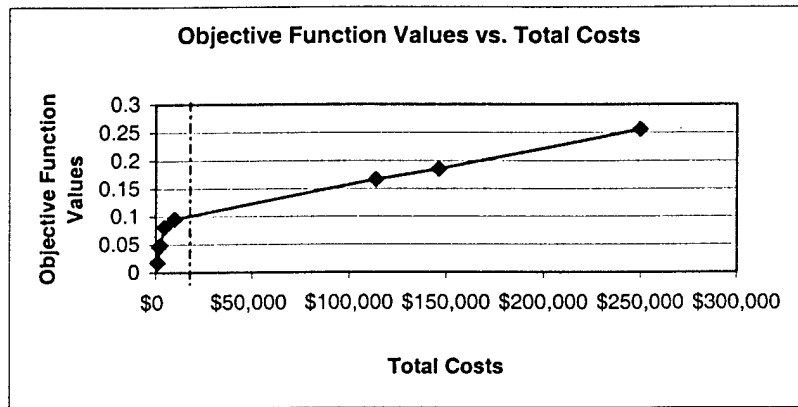

Figure 4.10 Effective sets comparisons

As Figure 4.10 shows, the first 5 sets (based on the changing modifications in the sets) get substantial benefit due to the higher slope of the figure. It is possible to produce a total benefit of 0.1 while spending less than 10 million dollars. However, after this point

the slope decreases dramatically due to total high total costs which means that the GE 100 engine modifications (A&B) require an extensive amount of money for the benefits they provide.

Integer programming techniques may be used successfully for budgeting profiles including other constraints. Time and capacity constraints may be added to the model. Political constraints may also be added to include decision-maker's opinions and concern in the study. An example would be implementing a GE engine modification for every 2 PW modifications. However, this is beyond the scope of the study and is not explained in detail in the research.

4.5 *What-If* Analysis

One question during the discussion of the weights was how the value model would react to the changes of sub-objectives' weights. Sensitivity analysis is performed to see the model stability for changing weights of the evaluation measures. What-if analysis tries to answer the changing concerns of USAF for the F-16 aircraft. The F-16 fighter can be used for purposes like training and testing in the future. Thus, combat capability may not be the biggest concern of the decision-maker. Safety or costs may become more important than combat capability due to the conditions in the Air Force. The global weights of safety and operations cost objectives were varied to see the ranking differences for the modifications. Table 4.16 shows the results for the first case. Safety is considered as the most important concern in the first case with a global weight of 0.5.

Table 4.16 What-If Case 1

Global Weights Safety = 0.5
 Operational Cost = 0.2
 Combat Capability= 0.3

Engine Type	Alternative	Value
	Hypothetical Best	0.704
GE 129	Laser Shock Peen	0.420
PW 229	2nd Fan Stator	0.309
GE 100	DEC Upgrade(30)	0.302
GE 100	DEC Upgrade(40)	0.302
GE 129	Frame Outer Liner	0.274
GE 100	Ejector Nozzle (40)	0.245
PW 229	# Bearing Seals	0.176
PW 229	Oil Filter Housing	0.175
GE 100	Ejector Nozzle (30)	0.164
PW 229	Fuel Nozzle Dump	0.138
PW 229	2nd Turbine Blade	0.130
PW 229	Rear Fun Duct Patch	0.026
	Hypothetical Worst	0.018

The *Laser Shock Peen for GE 129* is the closest modification to the hypothetical best case. Safety being the most important concern, *2nd Fan Stator for PW 229 and DEC upgrade (Block30/40) for GE 100* are the other important modifications for the F-16 aircraft.

The performance of the modifications in the sub-model mainly depends on the data. To see the ranking changes for the F-16 Capability Enhancement Model, the decision weights must be incorporated to the model. Using decision weights may provide better insights for the decision-maker depending on the changing preferences. The Fleet Size scenario is used as an example to see the overall ranking changes. Table 4.17 shows the results for the overall ranking.

Table 4.17 The Ranking for Fleet Size (What-If Case 1)

Engine Type	Alternatives	Block	Benefit
GE 100	DEC Upgrade	30-40	0.1274
GE 100	Ejector Nozzle	30-40	0.0827
GE 129	Laser Shock Peen	50	0.0529
GE 129	Turbine Frame Outer Liner	50	0.0345
PW 229	2nd Fan Stator	52	0.0117
PW 229	#4 Bearing Seals	52	0.0067
PW 229	Oil Filter Housing	52	0.0067
PW 229	Fuel Nozzle Damping	52	0.0052
PW 229	2nd Turbine Blade	52	0.0049
PW 229	Rear Fan Duct Patch	52	0.0010

The overall ranking for the fleet size does not change when the global weight of the safety is changed to 0.5 (compare the Table 4.16 and Table 4.5). The difference between the global weights of the safety and combat capability is not big enough to create changes in the rankings. This is due to the overall decision weights defined by the decision-maker. The sub-model ranking changes are reversed by the decision weights (top tier). This interaction limits the impact of the sub-model global weights.

The second case focuses on the operations cost of the modifications. The global weight of the operations cost was changed to 0.5 for this scenario. The global weight for the safety is 0.3. Combat capability is considered the least important objective for this case. Table 4.18 demonstrates the results for sub-model.

Table 4.18 What-If case 2

Global Weights Safety = 0.3
 Operations Cost = 0.5
 Combat Capability= 0.2

Engine Type	Alternative	Value
	Hypothetical Best	0.891
GE 100	Ejector Nozzle(40)	0.609
GE 100	Ejector Nozzle(30)	0.407
GE 129	Laser Shock Peen	0.406
GE 100	DEC Upgade(30)	0.361
GE 100	DEC Upgade(40)	0.361
PW 229	2nd Fan Stator	0.338
GE 129	Frame Outer Liner	0.308
PW 229	Oil Filter Housing	0.253
PW 229	# Bearing Seals	0.252
PW 229	2nd Turbine Blade	0.239
PW 229	Fuel Nozzle Dump	0.224
PW 229	Rear Fun Duct Patch	0.158
	Hypothetical Worst	0.151

The best alternative for the cost is *Ejector Nozzle for GE 100(Block 30/40)* engines. The *Laser Shock Peen and DEC upgrades for block 30 and 40* were other critical modifications in the sub-model.

Incorporating the decision weights into the model gives us a better comparison capability. The overall model ranking (ranking for F-16 Capability Enhancement Model) is shown in Table 4.19. The decision weights may provide better insights for the decision-maker depending on the changing preferences. The fleet size scenario is used as an example to see the overall ranking changes.

Table 4.19 Ranking for Fleet Size (What-If Case 2)

Engine Type	Alternatives	Block	Benefit
GE 100	Ejector Nozzle	30-40	0.2055
GE 100	DEC Upgrade	30-40	0.1523
GE 129	Laser Shock Peen	50	0.0512
GE 129	Turbine Frame Outer Liner	50	0.0388
PW 229	2nd Fan Stator	52	0.0128
PW 229	Oil Filter Housing	52	0.0096
PW 229	#4 Bearing Seals	52	0.0096
PW 229	2nd Turbine Blade	52	0.0091
PW 229	Fuel Nozzle Damping	52	0.0086
PW 229	Rear Fan Duct Patch	52	0.0060

Due to its low operations costs, *GE 100 Ejector Nozzle (Block 30/40)* is the most important modification in the list. Other GE 100/129 engine modifications follow this modification. However, small changes in the global weights of objectives do not severely change the overall rankings. When the decision weights were defined as the fleet size ratios (normalization explained previously), the GE 100/129 engine modifications are the winners and are still highly ranked in this scenario.

The final subject in this chapter is the sensitivity analysis of the study. Sensitivity analysis helps to determine how sensitive the value model is to the weights defined by the decision-maker in the sub-model. The decision weights are used in this part of the study as explained previously.

4.6 Sensitivity Analysis

Sensitivity analysis is done by changing the global weights of the evaluation measures. These weights represent the relative importance that is attached to changes in the different evaluation measures. Making these global weight changes for one evaluation measure result in changing the global weights for other evaluation measures. For example, increasing the global weight of UER drivers in Figure 4.11, below, results in decreasing the global weights of the other evaluation measures. If large changes in the ranking happen due to the small weights changes, the sub-model is considered weight sensitive. Otherwise, the sub-model is insensitive and allows room for error when determining decision-maker weights. Figure 4.11 represents the sensitivity analysis' results for aircraft availability (UER drivers). However, this research was planned as a pilot study, thus the sensitivity graphs may only provide information about the sensitivity of the sub-model to changes in the weights. The data gaps and lack of a final decision-maker represent the main disadvantages of the model. Therefore, these graphs are displayed to demonstrate the sensitivity analysis technique.

The vertical line in Figure 4.11 shows the current weight setting. Crossing alternative lines show the changes in the rankings based on the new weighting settings. Thus, the rankings are sensitive to the weight changes for UER Drivers evaluation measure. Appendix C shows the results for sensitivity analysis for other evaluation measures.

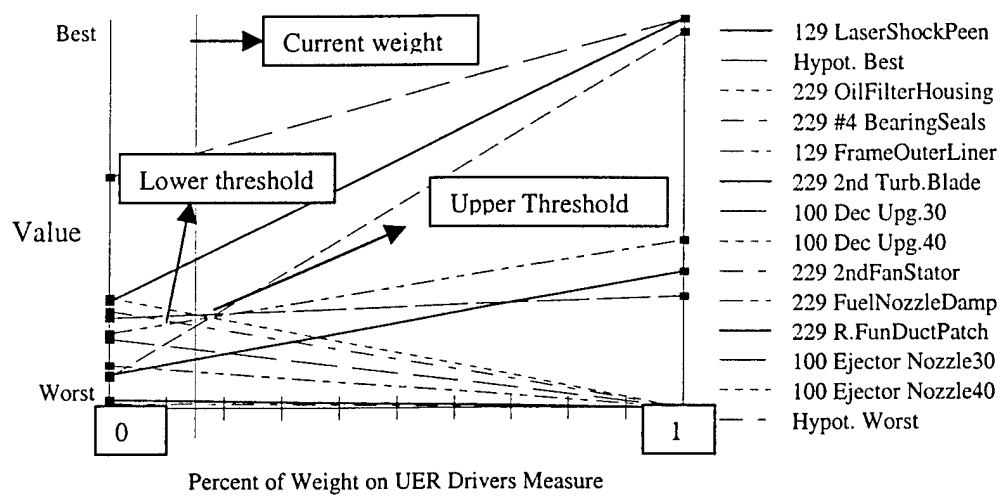

Preference Set = F-16 Capability Enhancement Model

Figure 4.11 Sensitivity of Weight for UER Drivers

The main point of the sensitivity analysis is to demonstrate the significance of the weightings. Model users should remember this property of the analysis. The decision-maker and the experts of the problem should define the weights of the model depending on the need of the USAF for better use of the model. The F-16 organizations using the model must be careful weighting the hierarchy.

4.7 Summary

The F-16 Capability Enhancement Model was applied to analyze ten different aircraft modifications for different purposes. The alternatives were ranked by the benefit they provide for the aircraft under different considerations. The acquisition costs were incorporated into the model to show the benefit per engine. The benefit/cost ratio was

applied to explain the benefit per dollar invested. The benefit/cost ratio greedy algorithm was used to provide better insights about the modifications' total acquisition costs.

Integer programming was used to find an optimal portfolio for the F-16 aircraft.

Different effective sets were introduced and total costs analyses were done.

What-if and sensitivity analysis helped to understand the stability of the model to the changes in the weights. Two different scenarios were used in the what-if analysis. In the first case, safety was accepted as the most important concern. In the second case, operations costs were defined as the most critical issue. The sub-model was found to be weight sensitive. However, when the decision weights were incorporated to the model, the rankings did not change significantly. Sensitivity analysis showed that the sub-model was weight sensitive and highlighted the need for careful weighting.

Chapter 5 explains the overall conclusions and includes advice for future researches.

Chapter 5: Conclusions

5.1 Introduction

The objective of this study was to select the best engine modifications for F-16 capability enhancement. This single objective, which is defined easily, is not a simple target to achieve. This single objective is composed of multiple attributes. The research showed that extensive effort was needed, requiring a detailed literature review, development of a complex model, and analysis to provide the answer.

Value focused thinking was demonstrated as a potential tool for solving this multiattribute decision problem. This thesis effort provides a way of organizing and understanding the data to make decisions for aircraft modification selection. The following section explains the big picture of the entire process.

Research and development organizations have to rationalize their decisions depending on their values. Chapter 1 explained this issue and explained the difficulty of this problem due to multiple aspects. An organized data gathering process and modeling approach is needed to help the decision-maker.

Chapter 2 began with a detailed discussion about safety, operational cost, and combat capability for F-16 aircraft. The importance of decision analysis was also explained. Technology selection models were examined after the discussion about decision analysis. VFT and AHP techniques were studied. VFT was selected due to its theoretical foundations and its unique ability to allow *PrOACT* thinking. Examples of

VFT were introduced to show its capabilities. The chapter was completed with the characteristics and limitations of the past technology selection models.

The VFT methodology was explained in Chapter 3. The overall framework was identified. The model building process was examined to give better insights about the development process. A modified VFT approach was elucidated to improve the flexibility of the model. Next, the values of the F-16 organizations were clarified. Single dimensional value functions and weights were solicited to complete the chapter.

In Chapter 4, ten modifications were analyzed in three different scenarios identified by the decision-maker. The goal was to determine which modifications provide the most benefit to the F-16 aircraft. Cost of modifications was introduced as another aspect the problem. Optimization methods were used to minimize the impacts of budget constraints. Finally sensitivity analysis showed that the model was sensitive to the changes in the weights. The decision-maker was provided the needed insights from the model to aid in the modification selection process.

5.2 Conclusions

The dimensions of the decision problem (specific to the F-16) were defined as the anticipated values of the ACC. The importance of an organized data gathering process was highlighted during the study by F-16 SPO and other organizations involved in the process. A mathematical model was developed by using the anticipated values of the ACC. This model provided a systematic approach to decision-making process and improved their current techniques. The model was used to identify the benefits of the

modifications. The costs for modification were involved in the process to demonstrate the possibility of changing benefits per dollar invested. Optimization techniques were used to show that selecting a portfolio of best modifications was possible for F-16 aircraft. The simplified case study proved that the multiattribute decision-making techniques could be applied to ASC and other organizations' decisions. VFT successfully analyzed ten engine modifications. The model built in this study can save time and valuable dollars of the F-16 organizations. The most important impact of this research is providing an objective, scientific decision support system for the ASC.

GE 100/129 engine modifications are the most beneficiary modifications for the F-16 aircraft. However, they score poorly when cost is a big driver for the decision. The costs of the GE 100/129 engine modifications must be decreased for better results. PW engine modifications have mainly low acquisition costs. Due to their low acquisition costs, they are more applicable for low cost budgeting profiles.

ASC should implement this method for selecting different modifications. The model should be expanded, validated, and verified by the model users. This research provides structure and guidance to implement this decision analysis approach.

5.3 Recommendations for future research

The data gathering process is one of most important parts of the problem. The consequences of valid data gathering on the study must be understood by the organizations. The time and effort required to gather the relevant data are extensive.

Time was a limiting aspect of this research. The F-16 aircraft data must be improved to relax some of the data assumptions explained in Chapter 3.

The assumption of modification independence should be reviewed. However, emphasis should be placed on the data gathering process as it is time consuming and complex. Thus, relaxing many assumptions will depend on the data improvements versus the analysis. The F-16 organization or users of the model must recognize these limitations and expend time, money, and man-hours to solve these problems.

This process provides a new approach to select a portfolio of modification. It is a top-down approach to show that VFT can be applied to F-16 decision-making processes. The model represents the general aspects of the problem. Future research can break the problem into small sections and construct more robust, separate models. Individual hierarchies will catch more detail and address issues that are not involved the original model.

Other multiattribute decision techniques can be applied to this problem for comparisons with VFT. These comparisons may provide additional insight to build an overall model and analyze results. Even AHP, with known limitations, may be applied to problem and results may provide different insights for the decision-maker. The decision weights must be defined clearly since they change the rankings of the alternatives due to various preferences of the decision-maker. The decision weights of the model can be determined using another multiattribute decision-making techniques to help the decision-maker.

The involvement of the decision-makers and experts from different organizations is vital in this process. The key elements (values) of the F-16 Capability Enhancement

model should be examined by the high-level decision-makers and experts from different F-16 organizations. It is possible that some of the means objectives can be replaced with the ends objectives.

The model used in the study is designed for the engine modifications only. Future research should broaden the scope of the study to the all modifications that enhance the combat capability of the F-16 aircraft. It is clear that the hierarchy will change, especially at the lower levels (evaluation measures) if the alternative set includes different modifications.

This effort should be expanded to the other fighter aircraft after the validation and verification process. The goal is to build an overall model for ACC to select alternatives that enhance the capabilities of the war fighter in a proven scientific fashion. However, this is only possible if representatives from each organization are involved in the process and discuss their values and the overall values of ACC. A final model could be built to support the decision-making process of ACC.

Finally, the areas for uncertainty in the model must be identified for future studies. The experts and decision-makers' opinions about the uncertainties should be implemented in the model. Uncertainties may cause ranking changes among the modifications depending on their probabilities.

5.4 Lessons Learned

This section explains the key elements in the decision-making process. The first step in the process is building a team for the problem. The team or analyst (student)

should pick an overall lead and a lead per organization. It helps in assigning the responsibilities. Communications between student and leaders should begin before the first meeting to find the support needed for the research. The student must identify the key decision-maker in the process prior to first meeting. The student has to keep in mind that solving the multiattribute decision-making problem is a team effort. Thus, an agenda must be set including schedule, topics, desired attendees, and, expected results to make sure every team member can adequately prepare. Their area of expertise and background might be valuable to fill the communication gaps among team members.

The first meeting is the most important meeting in many aspects. All key players in the problem must be involved in this meeting. The problem must be defined clearly. The scope of the study must be identified. Support in terms of time and money for the study must be described by the team. The expected results must be reviewed to set a clearly defined goal. The analyst has to understand the deliverables of the decision-maker in the first meeting. The time and contents of the deliverables might be modified later in the project.

Scheduling is a very important issue for stakeholders in the project. The student must keep in mind that clients are worried about solutions not graduation. The student has to set the schedule due to his or her needs, like workload of classes, ability, and etc. The timing and contents of the schedule must be modified due to the changing needs of the stakeholders. The documentation of the schedule and meetings help the team to keep track of the study.

The analyst must keep in mind that the advisor is one of the most critical players in the game. The analyst has to keep the advisor up-to-date. Complex problems may

arise during the process and the experience of the advisor may be helpful. If needed, advisors may be involved in the process as a part of the team. After all, the decision-making process may benefit from additional experiences in the academics of multi criteria decision-making.

The following equation represents a good decision-making process:

$$\text{Effective Decision} = \text{Quality Thinking} * \text{Acceptance}$$

(Dr. Deckro: Synergistic decision making brief)

5.5 Summary

This chapter explains the framework used for this research. The conclusions are abridged as the result of analysis done for the study. The possible areas for improvement were identified to help the future researches. The process steps were reviewed to help future analyst. The key elements were identified to complete the chapter.

APPENDIX A: F-16 Engines

Engine Model: PW -F-100 Family

The F100 family of engines powers the F15A-E models and the F16 A-D models. The F100 is the only engine to power the F15 in operational service and has the fantastic record of 100.5 aircraft shot down without ever losing an F15 in combat. The F16 is the front line air to ground aircraft for the USAF. The F100 continues to be the safest fighter engine in history with excellent reliability. The F100 family of fighter engines evolved from Pratt & Whitney's tradition of dependable engines. The first F100 entered service in 1974. More than 6,400 F100s, in the air forces of the United States and 17 other nations, have accumulated more than 14 million engine flight hours. The F100-PW-220 is the successor to the F100-PW-100 that powers the twin-engine Boeing F-15 and single-engine Lockheed Martin F-16 fighters. An increased performance engine, the F100-PW-229, joined the U.S. Air Force fleet in 1991. It provides 22 percent greater takeoff thrust for the Air Force's F-15E dual role fighter and for new F-16s (C/D models). The improved version can be installed in all previous F-16 models. Pratt & Whitney is developing an upgraded version of the PW-229, called the F100-PW-232, which features a larger and more efficient fan.

PW Military Engines on line available at

<http://www.pratt-whitney.com>

Engine Model: F110-GE-100 and F110-GE-400

Description: The F110-GE-100 was developed to provide greatly increased performance for later models of the F-16. The F110-GE-100 has demonstrated unrestricted throttle movement and stall-free operation in service, and has set the benchmark for single-engine fighter reliability and safety.

The F110-GE-400 was selected by the US Navy to re-engine their existing F-14A fleet (transforming them into F-14Bs) and to be the production standard engine for new F-14D aircraft. The -400 powered F-14s have increased range, endurance, maneuverability, and can make carrier takeoffs without the use of afterburning.

Engine Model: F-110-GE-129

Description: The F110-GE-129 is a derivative of the proven F110-GE-100 providing increased performance, enhanced durability and even greater reliability. New features include a full authority digital electronic control and advanced turbine materials. Capitalizing on the success of the F110-GE-100, the -129 retains 84% of that engine's basic hardware and engine architecture, which were designed with significant future growth capability. Since entering service in 1992, the F110-GE-129 has proven to be the most successful fighter engine in USAF history.

Because of the F110 engine's proven safety track record and heritage of high reliability, the F110-GE-129 has been chosen to power more than 75% of the USAF's single engine F-16 Block

50/52* aircraft. Having accumulated more than 400,000 flight hours in the Block 50, the F110-GE-129 has established a track record of excellence that is unmatched by any engine in its class. Due to its inherent design and GE's unyielding emphasis on six sigma quality, the engine has demonstrated unmatched levels of on-wing performance retention. No F110-GE-129 has ever been removed from service due to insufficient performance! The F110-GE-129 has also been the choice of the Turkish, Greek, and Japanese air forces to power their single engine F-16s. 434 production units have been shipped to date. The -129 is also qualified on the F-15E Strike Eagle and recently completed a highly successful field service evaluation on this application.

GE Military Engines online available at

<http://www.geae.com/military>

APPENDIX B: Metamorphoses of the model

This appendix explains the different models and their problems created to select the best engine modifications. Our team agreed that Combat Capability, Safety and Operational Cost were the critical objectives of the model. The first model is shown in Figure 1.

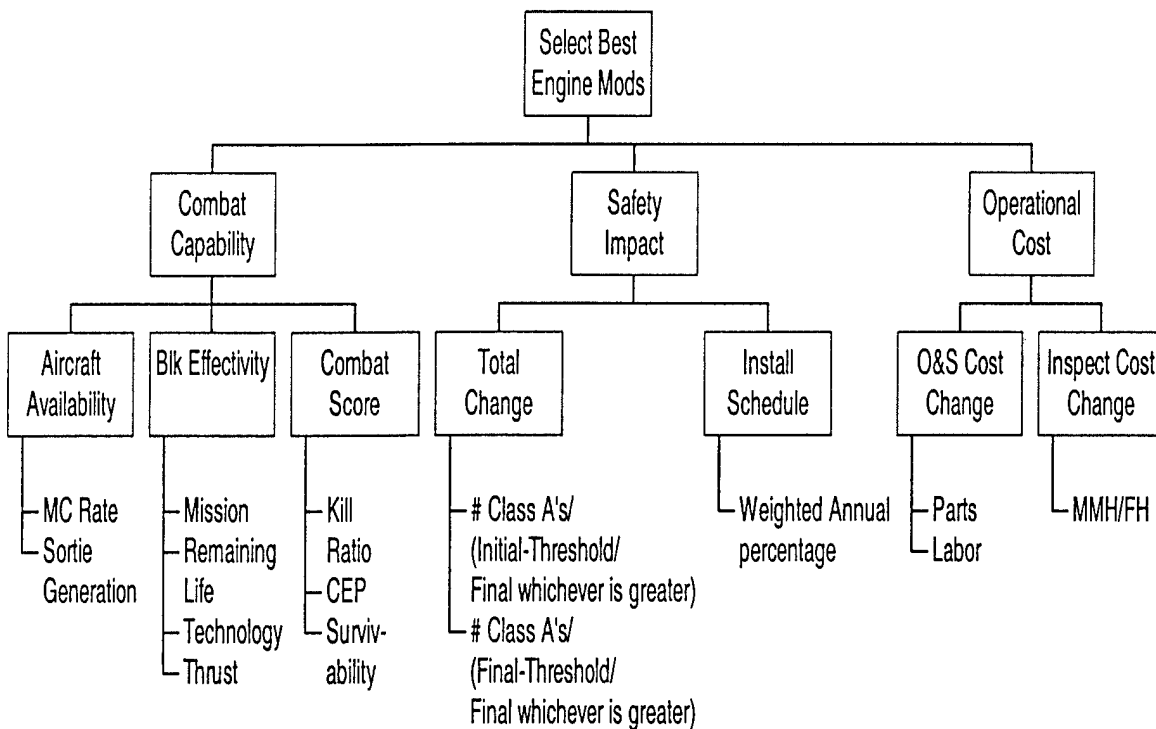

Figure 1 The First Value Model

Some problems and concerns emerged after testing the model's robustness for the different aspects of ACC's decision-making process. The main problems were:

- How to deal with the number of aircraft effected by a specific modification.
- How to deal with the special missions flown by specific block of F-16.

Normalization by aircraft number at the end of the model was one solution considered for solving the first problem. The solution to the second problem was thought

to have been already addressed in the model by the metric for mission type. The example shown in Table 1 help us understand the problem better.

Table 1 Example for the first model problem

Modification Type	Type of A/C affected	Normalization Value	The value for fundamental objective	Final Value (The value after normalization)
A	Block 30	$600/1400=0.43$ (Number of Block 30 divided by Total A/C number)	0.4	$0.4*0.43 = \mathbf{0.17}$
B	Block 50	$50/1400=0.035$ (Number of Block 50 divided by Total A/C number)	0.8	$0.8*0.035 = \mathbf{0.03}$

Modification A was considered better than B, because it affected more aircraft. However, the decision-maker said that this assumption was not completely true since ACC and F-16 SPO would be willing to select modification B to modify Block 50 aircraft. Block 50 aircraft fly a very critical mission called suppression of enemy air defense (SEAD).

The first solution to the problem was basically changing the value model so that we could give more value to the mission type. The second model, as shown in Figure 2, was developed to capture the decision- maker's opinions.

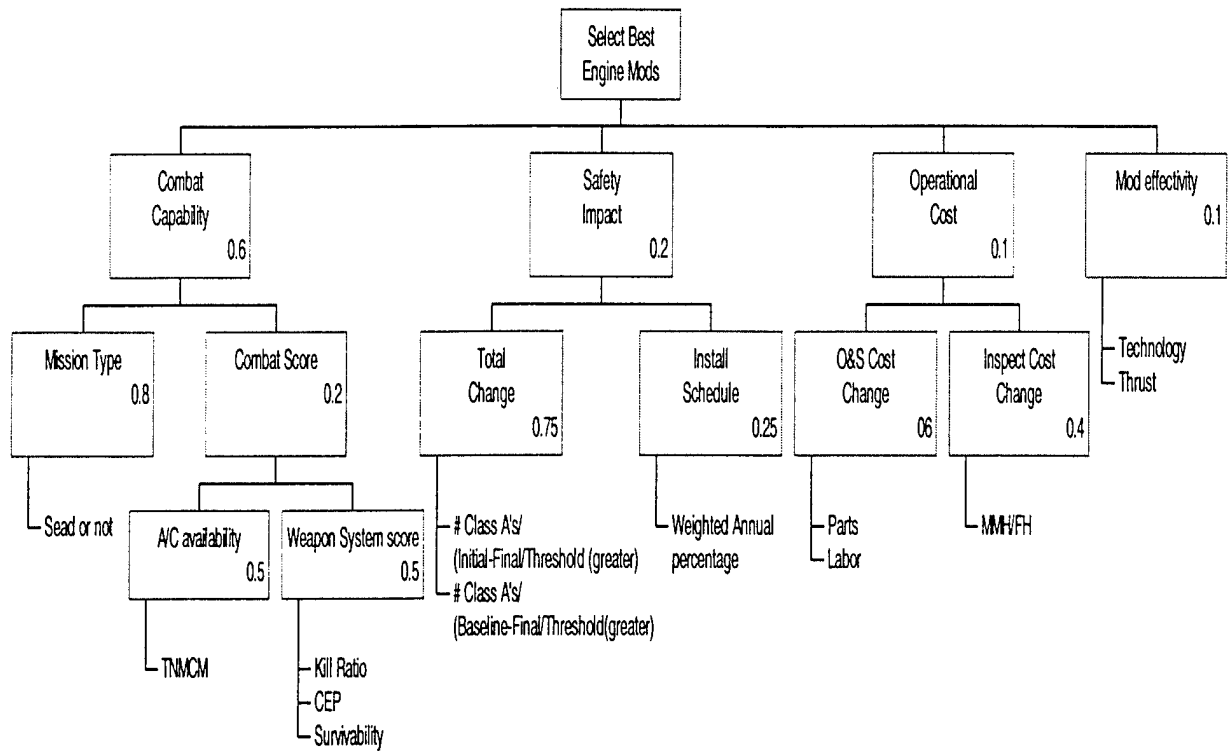

Figure 2 A Solution to the Mission Type Problem

Mission type in this model had a global weight of 0.48 (0.6×0.8). The metric for Mission type was planned to be a discrete function. It was a simple yes/ no question for the calculations. Thus, if any modification affected the SEAD, it would get a total value of 0.48 for combat capability and possibly reach a score of 1 for total. If a modification was not effecting SEAD, it would get 0 for combat capability and possibly reach a total score of 0.52 in a best case. However, normalization by aircraft would give a lower score for Block 50 (only the blocks that can fly the SEAD) since they had a very small fleet size compared to other blocks no matter how we the model was changed. Therefore, the model was not approved as a solution to the problem, and a better and more flexible solution was needed.

Further studies and examination of the model created the second solution. New metrics were added to the model. A higher-level tier was connected to the model to deal with mission and aircraft numbers. The second solution, (a modified VFT approach) is shown in Figure 3.

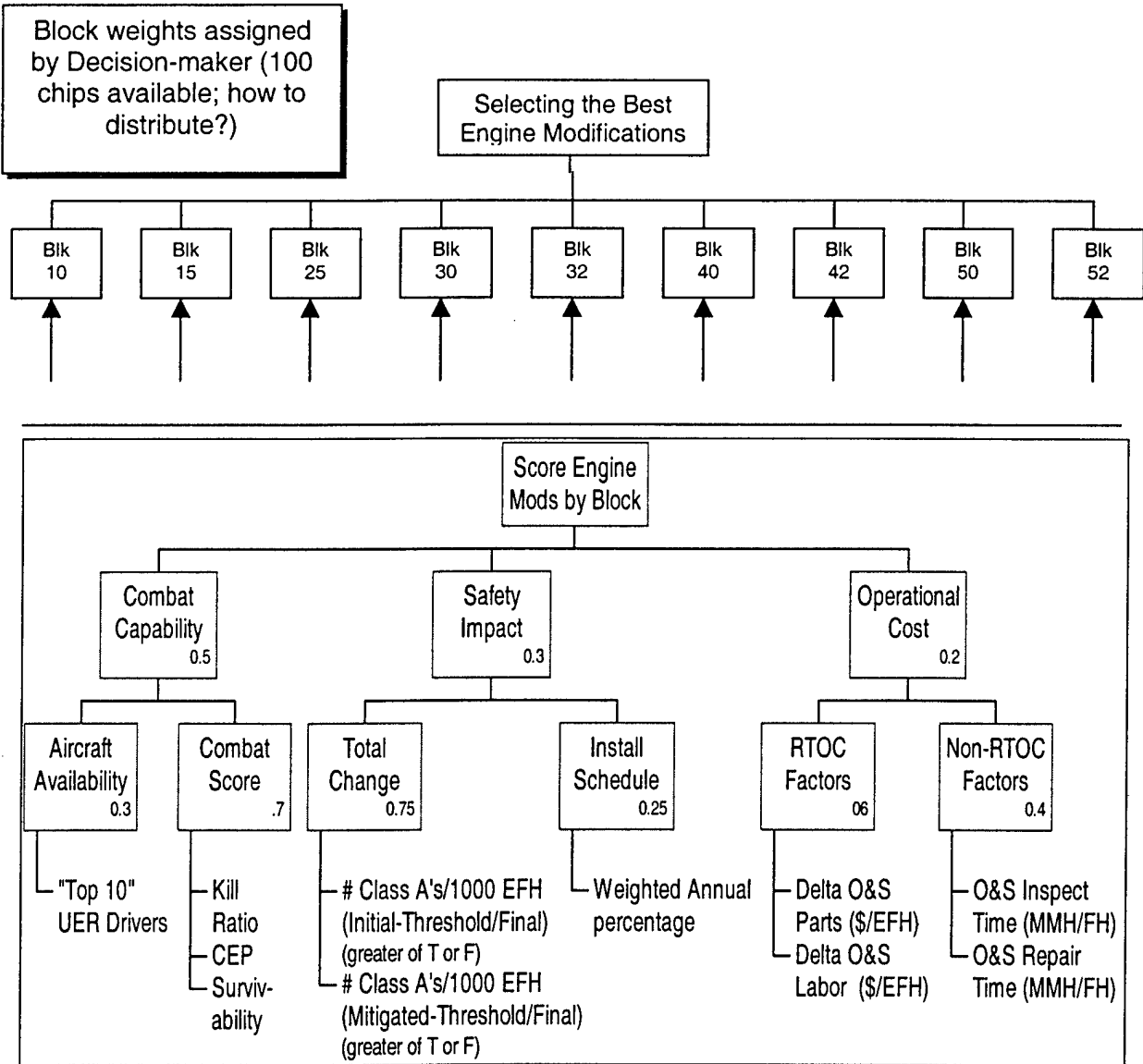
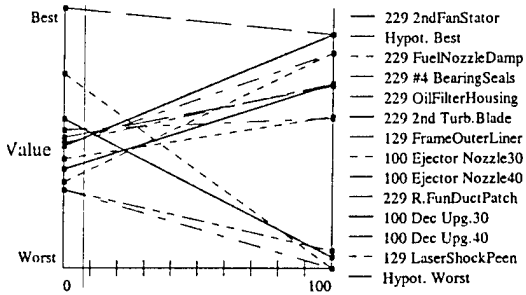

Figure 3 Final Model

APPENDIX C: Sensitivity Analysis Graphs

The sensitivity analysis graphs show the model sensitivity to the changes in the weights.

The graphs, shown below, demonstrate that our sub-model is weight sensitive.



Percent of Weight on Wtd Annual Percentage Measure

Preference Set = F-16 Capability Enhancement Model

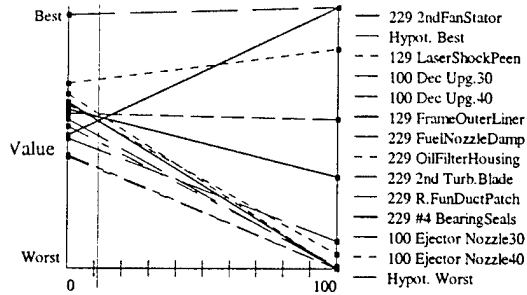

Percent of Weight on Class A's(I-T/F) Measure

Preference Set = F-16 Capability Enhancement Model

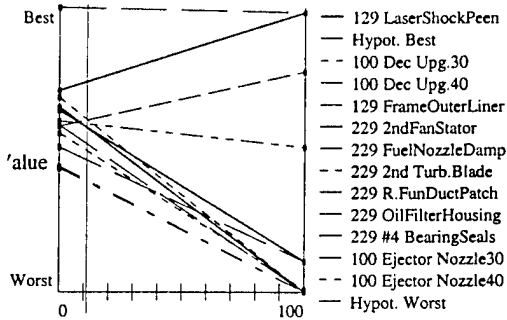

Percent of Weight on Class A's(M-T/F) Measure

Preference Set = F-16 Capability Enhancement Model

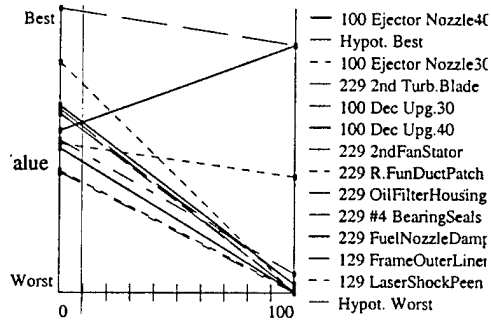

Percent of Weight on O&S Parts Measure

Preference Set = F-16 Capability Enhancement Model

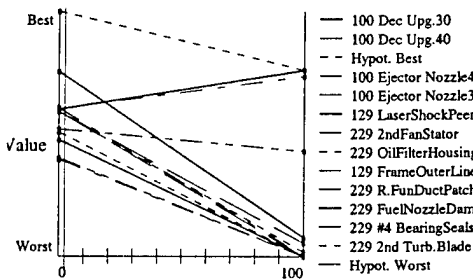

Percent of Weight on O&S Labor Measure

Preference Set = F-16 Capability Enhancement Model

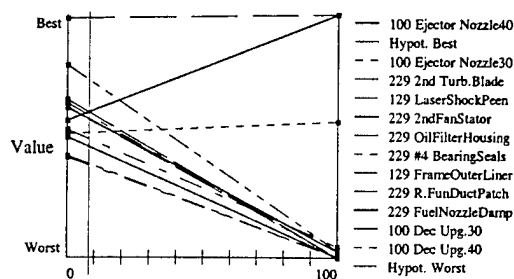

Percent of Weight on MMH Measure

Preference Set = F-16 Capability Enhancement Model

The graphs for MMH and O&S Parts are weight sensitive to the decreases in the overall weights. On the other hand, WAPM is weight sensitive to the increases in the weights. Number of Class A's(I-T/F), and Number of Class A's(M-T/F) evaluation measures are sensitive to both increases and decreases. O&S Labor is the only evaluation measure that can have room for errors. The model users should remember this property of the analysis. The decision-maker and the experts of the problem should define the weights of the model depending on the need of the USAF for better use of the model. The F-16 organizations using the model have to be careful about the weighting process.

APPENDIX D: Modifications' Data

Tables, shown below, demonstrate the data for modifications used in the process. The data are separated for block types as it is used for the sub-model.

Table 1 PW 229 Oil Filter Housing

Engine Groundrules Data	
# Aircraft (Installed Engines)	65
# Spare Engines/Modules	12
Engine Flight Hours / Month	23
Throttle Acceleration Cycles / Engine Flight Hours	2.29
Steady State Years	25
Total estimated remaining EFH for fleet	448,500
Hourly Depot Labor Rate	\$85
Baseline NRIFSD / 100,000 EFH	0.05
Baseline Class A / 100,000 EFH	0.05
Block Effectivity	52

	Safety Inputs		ECP Data		
	Initial	Mitigated	Proposed	Delta 1	Delta 2
Non-Recoverable In-Flight Shut-Downs / 100K EFH	0.124	0.050	0.005		
Class A Events / 100K EFH	0.098	0.050	0.004	0.048	0.000
Hardware Cost	Current \$1,101	Proposed \$2,513			
Depot Replacement Interval (hrs)	3000	3000			

Depot Scrap Rate	100%	100%	100%
Depot Labor to Remove & Replace (Hrs)	44	44	44
Lifetime Depot Hardware Replacements	150	150	150
Lifetime Depot Labor Hours	6578	6578	6578
Field Unscheduled Event Rate (Events / 1000 EFH)	0.011	0	0
Field Scheduled Event Rate (Events / 1000 EFH)	0.0000	0.0000	0.0000
Total Field Event Rate (per 1000 EFH)	0.0110	0.0000	0.0000
Field Scrap Rate	100%	100%	100%
Field Labor to Remove & Replace (Hrs)	<u>35.5</u>	<u>108.9</u>	<u>108.9</u>
Remove Engine	19	19	19
Remove & Replace Hardware	10	83.4	83.4
Engine Test	6.5	6.5	6.5
Lifetime Field Hardware Replacements	4.93	0.00	0.00
Lifetime Field Labor Hours	175	0	0
Field Inspection Rate (Events / 1000 EFH)	20.0000	0.0000	0.0000
Labor Hours per Inspection	0.25	0.00	0.00
Lifetime Field Inspections	8970	0	0
Lifetime Field Inspection Hours	2243	0	0

RTOC Data

Lifetime Hardware Avoided	\$	5,432
Miscellaneous Hardware Cost Avoidance	\$	64,189
Lifetime Depot Labor Avoided	\$	-
Total Lifetime Cost Avoidance	\$	69,621
Hardware \$ / 1000 EFH	\$	155.23
Labor \$ / 1000 EFH	\$	-

Non-RTOC Data

Lifetime Field Maintenance Avoided (MMH) 175
 Lifetime Field Inspection Hours Avoided (MMH) 2,243
 Total Maintenance Hours Avoided 2,418
 MMH / 1000 EFH Avoided due to modification 5.39

Safety Data

Does Mod Get Problem Below Safety Threshold? YES
 Delta Class A Rate (Initial - Mitigated) 0.048
 Delta Class A Rate (Mitigated - Proposed) 0.046

Retrofit Cost

Unit Kit Cost (includes depot installation labor) \$ 2,513
 Install Engines Retrofit Cost \$ 163,345
 Spare Engines Retrofit Cost \$ 30,156
 Total Retrofit Cost \$ 193,501

Installation Schedule

	# Engines	Fleet %	Values
Year 1	24	37%	1
Year 2	24	37%	0.8
Year 3	17	26%	0.6
Year 4	0	0%	0.4
Year 5			0.2

Total 65 100%

Total weighted Annual Percentage	0.822
----------------------------------	-------

Table 2 PW 229 2nd Fan Stator

Engine Groundrules Data	
# Aircraft (Installed Engines)	65
# Spare Engines/Modules	12
Engine Flight Hours / Month	23
Throttle Acceleration Cycles / Engine Flight Hours	2.29
Steady State Years	25
Total estimated remaining EFH for fleet	448,500
Hourly Depot Labor Rate	\$85
Threshold NRIFSD / 100,000 EFH	0.05
Threshold Class A / 100,000 EFH	0.05
Block Effectivity	52

	Initial	Mitigated	Proposed	Delta 1	Delta 2
Safety Inputs					
Non-Recoverable In-Flight Shut-Downs / 100K EFH	0.878	0.179	0.046		
Class A Events / 100K EFH	0.694	0.141	0.036	0.644	0.091
ECP Data					
Hardware Cost	Current \$20,557	Proposed \$19,600			
Depot Replacement Interval (hrs)	4300	8600			
Depot Scrap Rate	100%	100%			
Depot Labor to Remove & Replace (Hrs)	44	44			
Lifetime Depot Hardware Replacements	104	52			
Lifetime Depot Labor Hours	4589	2295			
Field Unscheduled Event Rate (Events / 1000 EFH)	0.0045	0.0005			
Field Scheduled Event Rate (Events / 1000 EFH)	0.2389	0.0000			
Total Field Event Rate (per 1000 EFH)	0.2434	0.0005			
Field Scrap Rate	100%	100%			

Field Labor to Remove & Replace (Hrs)	<u>108.9</u>	<u>108.9</u>
Remove Engine	19	19
Remove & Replace Hardware	83.4	83.4
Engine Test	6.5	6.5
Lifetime Field Hardware Replacements	109.14	0.22
Lifetime Field Labor Hours	11886	24
Field Inspection Rate (Events / 1000 EFH)	0.0000	0.0000
Labor Hours per Inspection	0.00	0.00
Lifetime Field Inspections	0	0
Lifetime Field Inspection Hours	0	0

RTOC Data

Lifetime Hardware Avoided	\$ 3,311,125
Miscellaneous Hardware Cost Avoidance	\$ 64,189
Lifetime Depot Labor Avoided	\$ 195,045
Total Lifetime Cost Avoidance	\$ 3,570,359
Hardware \$ / 1000 EFH	\$ 7,525.78
Labor \$ / 1000 EFH	\$ 434.88

Non-RTOC Data

Lifetime Field Maintenance Avoided (MMH)	11,861
Lifetime Field Inspection Hours Avoided (MMH)	0
Total Maintenance Hours Avoided	11,861
MMH / 1000 EFH Avoided due to modification	26.45

Safety Data

Does Mod Get Problem Below Safety Threshold?	YES
Delta Class A Rate (Initial - Mitigated)	0.552
Delta Class A Rate (Mitigated - Proposed)	0.105

Retrofit Cost

Unit Kit Cost (includes depot installation labor)	\$ 19,600
Install Engines Retrofit Cost	\$ 1,274,000
Spare Engines Retrofit Cost	\$ 235,200
Total Retrofit Cost	\$ 1,509,200

Installation Schedule	# Engines	Fleet %	Values
Year 1	36	55%	1
Year 2	29	45%	0.8
Year 3	0	0%	0.6
Year 4	0	0%	0.4
Year 5	0	0%	0.2
Total	65	100%	

Total weighted Annual Percentage	0.911
----------------------------------	-------

Table 3 PW 229 Fuel Nozzle Damping

Engine Groundrules Data	
# Aircraft (Installed Engines)	65
# Spare Engines/Modules	12
Engine Flight Hours / Month	23
Throttle Acceleration Cycles / Engine Flight Hours	2.29
Steady State Years	25
Total estimated remaining EFH for fleet	448,500
Hourly Depot Labor Rate	\$85
Baseline NRIFSD / 100,000 EFH	0.05
Baseline Class A / 100,000 EFH	0.05

Block Effectivity 52

	Initial	Mitigated	Proposed	Delta 1	Delta 2
Safety Inputs					
Non-Recoverable In-Flight Shut-Downs / 100K EFH	0.179	0.179	0.048		
Class A Events / 100K EFH	0.141	0.141	0.038	0.091	0.091
ECP Data					
Hardware Cost	\$55	\$55			
Depot Replacement Interval (hrs)	4300	4300			
Depot Scrap Rate	100%	100%			
Depot Labor to Remove & Replace (Hrs)	19	19			
Lifetime Depot Hardware Replacements	104	104			
Lifetime Depot Labor Hours	1930	1930			
Field Unscheduled Event Rate (Events / 1000 EFH)	0.124	0.05			
Field Scheduled Event Rate (Events / 1000 EFH)	0.0000	0.0000			
Total Field Event Rate (per 1000 EFH)	0.1240	0.0500			
Field Scrap Rate	83%	0%			

Field Labor to Remove & Replace (Hrs)	<u>39</u>
Remove Engine	19
Remove & Replace Hardware	18.5
Engine Test	1.5
Lifetime Field Hardware Replacements	0.00
Lifetime Field Labor Hours	0
Field Inspection Rate (Events / 1000 EFH)	0.0000
Labor Hours per Inspection	0.00
Lifetime Field Inspections	0
Lifetime Field Inspection Hours	0

RTOC Data

Lifetime Hardware Avoided	\$ 2,539
Miscellaneous Hardware Cost Avoidance	\$ -
Lifetime Depot Labor Avoided	\$ -
Total Lifetime Cost Avoidance	\$ 2,539
Hardware \$ / 1000 EFH	\$ 5.66
Labor \$ / 1000 EFH	\$ -

Non-RTOC Data

Lifetime Field Maintenance Avoided (MMH)	1,800
Lifetime Field Inspection Hours Avoided (MMH)	0
Total Maintenance Hours Avoided	1,800
MMH / 1000 EFH Avoided due to modification	4.01

Safety Data

Does Mod Get Problem Below Safety Threshold?	YES
Delta Class A Rate (Initial - Mitigated)	0.000
Delta Class A Rate (Mitigated - Proposed)	0.103

Retrofit Cost

Unit Kit Cost (includes depot installation labor)	\$	8,500
Install Engines Retrofit Cost	\$	552,500
Spare Engines Retrofit Cost	\$	102,000
Total Retrofit Cost	\$	654,500

Installation Schedule	# Engines	Fleet %	Factors
Year 1	30	46%	1
Year 2	30	46%	0.8
Year 3	5	8%	0.6
Year 4	0	0%	0.4
Year 5	0	0%	0.2
Total	65	100%	

Total weighted Annual Percentage	0.877
----------------------------------	-------

Table 4 GE 100 DEC Upgrade (Block 30)

Engine Groundrules Data						
# Aircraft (Installed Engines)	477					
# Spare Engines/Modules	0					
Engine Flight Hours / Month	17					
Throttle Acceleration Cycles / Engine Flight Hours	3					
Steady State Years	20					
Total estimated remaining EFH for fleet	3,312,960					
Hourly Depot Labor Rate	\$93					
Baseline NRIFSD / 100,000 EFH	0.05					
Baseline Class A / 100,000 EFH	0.05					
Block Effectivity						
						30
Safety Inputs						
		Initial	Mitigated	Proposed	Delta 1	Delta 2
Non-Recoverable In-Flight Shut-Downs / 100K EFH		0.471	0.471	0.04	0.322	0.322
Class A Events / 100K EFH		0.372	0.372	0.032	0.322	0.322
RTOC Data						
Lifetime Hardware Avoided	\$	25,756,037				
Miscellaneous Hardware Cost Avoidance	\$	12,448				
Lifetime Depot Labor Avoided	\$	13,185,492				
Total Lifetime Cost Avoidance	\$	38,953,977				
Hardware \$ / 1000 EFH	\$	7,778.09				
Labor \$ / 1000 EFH	\$	3,979.97				
						7,778
Non-RTOC Data						
Lifetime Field Maintenance Avoided (MMH)		8,022				
Lifetime Field Inspection Hours Avoided (MMH)		0				
Total Maintenance Hours Avoided		8,022				

MMH / 1000 EFH Avoided due to modification

2.42

Safety Data

Does Mod Get Problem Below Safety Threshold? YES
 Delta Class A Rate (Initial - Mitigated) 0.000
 Delta Class A Rate (Mitigated - Proposed) 0.340

Retrofit Cost

Unit Kit Cost (includes depot installation labor) \$ 170,700
 Install Engines Retrofit Cost \$ 81,423,900
 Spare Engines Retrofit Cost \$ -
 Total Retrofit Cost \$ 81,594,600

Installation Schedule

	# Engines	Fleet %	Factors
Year 1	86	18%	1
Year 2	86	18%	0.8
Year 3	86	18%	0.6
Year 4	86	18%	0.4
Year 5	0	0%	0.2
Total	344	72%	

Total weighted Annual Percentage 0.505

Table 5 GE 100 DEC Upgrade (Block 40)

Engine Groundrules Data

# Aircraft (Installed Engines)	321
# Spare Engines/Modules	0
Engine Flight Hours / Month	17
Throttle Acceleration Cycles / Engine Flight Hours	3
Steady State Years	20
Total estimated remaining EFH for fleet	3,312,960
Hourly Depot Labor Rate	\$93
Baseline NRIFSD / 100,000 EFH	0.05
Baseline Class A / 100,000 EFH	0.05

Block Effectivity	40
-------------------	----

Safety Inputs

Non-Recoverable In-Flight Shut-Downs / 100K EFH	Initial	Mitigated	Proposed	Delta 1	Delta 2
Class A Events / 100K EFH	0.471	0.471	0.04		
	0.372	0.372	0.032	0.322	0.322

RTOC Data

Lifetime Hardware Avoided	\$ 25,756,037	
Miscellaneous Hardware Cost Avoidance	\$ 12,448	
Lifetime Depot Labor Avoided	\$ 13,185,492	
Total Lifetime Cost Avoidance	\$ 38,953,977	
Hardware \$ / 1000 EFH	\$ 7,778.09	7778.09
Labor \$ / 1000 EFH	\$ 3,979.97	

Non-RTOC Data

Lifetime Field Maintenance Avoided (MMH)	8,022
Lifetime Field Inspection Hours Avoided (MMH)	0
Total Maintenance Hours Avoided	8,022

MMH / 1000 EFH Avoided due to modification

2.42

Safety Data

Does Mod Get Problem Below Safety Threshold? YES
 Delta Class A Rate (Initial - Mitigated) 0.000
 Delta Class A Rate (Mitigated - Proposed) 0.340

Retrofit Cost

Unit Kit Cost (includes depot installation labor) \$ 170,700
 Install Engines Retrofit Cost \$ 54,794,700
 Spare Engines Retrofit Cost \$ -
 Total Retrofit Cost \$ 54,965,400

Installation Schedule

	# Engines	Fleet %	Values
Year 1	58	18%	1
Year 2	58	18%	0.8
Year 3	58	18%	0.6
Year 4	58	18%	0.4
Year 5			0.2

Total

232 72%

Total weighted Annual Percentage 0.506

Table 6 PW 229 Rear Fun Duct Patch

Engine Groundrules Data							
# Aircraft (Installed Engines)		65					
# Spare Engines/Modules		12					
Engine Flight Hours / Month		23					
Throttle Acceleration Cycles / Engine Flight Hours		2.29					
Steady State Years		25					
Total estimated remaining EFH for fleet		448,500					
Hourly Depot Labor Rate		\$85					
Baseline NRIFSD / 100,000 EFH		0.05					
Baseline Class A / 100,000 EFH		0.05					
Block Effectivity				52			
Safety Inputs							
Non-Recoverable In-Flight Shut-Downs / 100K EFH	Initial	0.002	Mitigated	0.002	Proposed	0.000	Delta 1
Class A Events / 100K EFH	0.002	0.002	0.002	0.000	0.000	0.002	Delta 2
ECP Data							
Hardware Cost	Current	\$106,405	Proposed	\$108,531			
Depot Replacement Interval (TACS)	8000	8600	100%				
Depot Scrap Rate	100%	100%					
Depot Labor to Remove & Replace (Hrs)	19	19					
Lifetime Depot Hardware Replacements	56	52					
Lifetime Depot Labor Hours	1037	965					
Field Unscheduled Event Rate (Events / 1000 EFH)	0.331	0					
Field Scheduled Event Rate (Events / 1000 EFH)	0.0000	0.0000					
Total Field Event Rate (per 1000 EFH)	0.3310	0.0000					
Field Scrap Rate	0.30%	0%					

Field Labor to Remove & Replace (Hrs)	<u>32.5</u>	<u>32.5</u>
Remove Engine	19	19
Remove & Replace Hardware	12	12
Engine Test	1.5	1.5
Lifetime Field Hardware Replacements	0.45	0.00
Lifetime Field Labor Hours	14	0
Field Inspection Rate (Events / 1000 EFH)	4.5080	0.0000
Labor Hours per Inspection	1.00	0.00
Lifetime Field Inspections	2022	0
Lifetime Field Inspection Hours	2022	0

RTOC Data

Lifetime Hardware Avoided	\$ 463,574
Miscellaneous Hardware Cost Avoidance	\$ -
Lifetime Depot Labor Avoided	\$ 6,151
Total Lifetime Cost Avoidance	\$ 469,725
Hardware \$ / 1000 EFH	\$ 1,033.61
Labor \$ / 1000 EFH	\$ 13.71

Non-RTOC Data

Lifetime Field Maintenance Avoided (MMH)	14
Lifetime Field Inspection Hours Avoided (MMH)	2,022
Total Maintenance Hours Avoided	2,036
MMH / 1000 EFH Avoided due to modification	4.54

Safety Data

Does Mod Get Problem Below Safety Threshold?	YES
Delta Class A Rate (Initial - Mitigated)	0.000
Delta Class A Rate (Mitigated - Proposed)	0.002

Retrofit Cost

Unit Kit Cost (includes depot installation labor)		354
Install Engines Retrofit Cost	\$	23,010
Spare Engines Retrofit Cost	\$	4,248
Total Retrofit Cost	\$	27,258

Installation Schedule	# Engines	Fleet %	Values
Year 1	12	18%	1
Year 2	12	18%	0.8
Year 3	12	18%	0.6
Year 4	12	18%	0.4
Year 5			0.2
Total	48	74%	

Total weighted Annual Percentage	0.517
----------------------------------	-------

Table 7 PW 229 # 4 Bearing Seals

Engine Groundrules Data		Proposed	Delta 1	Delta 2
# Aircraft (Installed Engines)	65			
# Spare Engines/Modules	12			
Engine Flight Hours / Month	23			
Throttle Acceleration Cycles / Engine Flight Hours	2.29			
Steady State Years	25			
Total estimated remaining EFH for fleet	448,500			
Hourly Depot Labor Rate	\$85			
Baseline NRIFSD / 100,000 EFH	0.05			
Baseline Class A / 100,000 EFH	0.05			
Block Effectivity			0.000	0.000

Safety Inputs		Mitigated	Proposed	Delta 1	Delta 2
Non-Recoverable In-Flight Shut-Downs / 100K EFH	Initial	0.000	0.000		
Class A Events / 100K EFH	0.000	0.000	0.000		
ECP Data		Proposed			
<u>Scheduled</u>					
Scheduled Maintenance Interval (TACs)	Current	4300	4300		
Scheduled Maintenance Rate / 1000 EFH	0.698	0.698	0.698		
Scheduled O-Level Inspection Rate / 1000 EFH	0.000	0.000	0.000		
Scheduled Man-Hours per Inspection	0.0	0.0	0.0		
Scheduled % Removed at O-Level	0%	100%	100%		
Scheduled Man-Hours to R&R at O&I-Level	0.0	0.0	0.0		
Scheduled % at O&I-Level requiring Repair	0%	0%	0%		
Scheduled Repair Cost at O&I-Level	\$0	\$0	\$0		
Scheduled % Returned to Depot	0%	100%	100%		
Scheduled Man-Hours at Depot	0.0	0.0	0.0		

Scheduled % at Depot requiring Repair	0%	0%
Depot Repair Cost	\$0	\$0
Scheduled % Scrapped at Depot	0%	100%
Depot Hardware Scrap Cost	\$0	\$239
Lifetime Scheduled Hardware Repair Cost	\$0	\$0
Lifetime Scheduled Hardware Scrap Cost	\$0	\$74,820
Lifetime Scheduled Depot Labor (MMH)	0	0
Lifetime Scheduled Field Labor (MMH)	0	0

Unscheduled

Unscheduled Event Rate / 1000 EFH	0.060	0.012
Unscheduled % Removed at O&I-Level	100%	100%
Unscheduled Manhours to R&R at O&I-Level	92.2	86.2
Unscheduled Engine Test Time	1.5	0.0
Unscheduled % at O&I-Level requiring Repair	100%	100%
Unscheduled Repair Cost at O&I-Level	\$2,931	\$239
Unscheduled % Returned to Depot	0%	0%
Unscheduled Manhours at Depot	0	0.0
Unscheduled at Depot Requiring Repair	0%	0%
Unscheduled Repair Cost at Depot	\$0	\$0
Unscheduled % Scrapped at Depot	0%	0%
Depot Hardware Scrap Cost	\$0	\$0
Lifetime Unscheduled Hardware Repair Cost	\$79,399	\$1,295
Lifetime Unscheduled Hardware Scrap Cost	\$0	\$0
Lifetime Unscheduled Depot Labor (MMH)	0	0
Lifetime Unscheduled Field Labor (MMH)	2,538	467

RTOC Data

Lifetime Hardware Avoided	\$	3,284
Miscellaneous Hardware Cost Avoidance	\$	-

Lifetime Depot Labor Avoided	\$ -
Total Lifetime Cost Avoidance	\$ 3,284
Hardware \$ / 1000 EFH	\$ 7.32
Labor \$ / 1000 EFH	\$ -

Non-RTOC Data

Lifetime Field Maintenance Avoided (MMH)	2,071
Lifetime Field Inspection Hours Avoided (MMH)	0
Total Maintenance Hours Avoided	2,071
MMH / 1000 EFH Avoided due to modification	4.62

Safety Data

Does Mod Get Problem Below Safety Threshold?	YES
Delta Class A Rate (Initial - Mitigated)	0.000
Delta Class A Rate (Mitigated - Proposed)	0.000

Retrofit Cost

Unit Kit Cost (includes depot installation labor)	\$ 633
Install Engines Retrofit Cost	\$ 41,145
Spare Engines Retrofit Cost	\$ 7,596
Total Retrofit Cost	\$ 48,741

Installation Schedule

Installation Schedule	# Engines	Fleet %	Values
Year 1	30	46%	1
Year 2	30	46%	0.8
Year 3	5	8%	0.6
Year 4	0	0%	0.4
Year 5			0.2

Total

65

100%

Total weighted	
Annual Percentage	0.877

Table 8 2nd Turbine Blade

Engine Groundrules Data					
# Aircraft (Installed Engines)		65			
# Spare Engines/Modules		12			
Engine Flight Hours / Month		23			
Throttle Acceleration Cycles / Engine Flight Hours		2.29			
Steady State Years		25			
Total estimated remaining EFH for fleet		448,500			
Hourly Depot Labor Rate		\$85			
Baseline NRIFSD / 100,000 EFH		0.05			
Baseline Class A / 100,000 EFH		0.05			
Block Effectivity					
					52

	Safety Inputs	Initial	Mitigated	Proposed	Delta 1	Delta 2
	Non-Recoverable In-Flight Shut-Downs / 100K EFH	0.018	0.018	0.005		
	Class A Events / 100K EFH	0.014	0.014	0.004	0.010	0.010
	ECP Data	Current	Proposed			
	<u>Scheduled</u>					
	Scheduled Maintenance Interval (TACs)	4300	4300			
	Scheduled Maintenance Rate / 1000 EFH	0.698	0.698			
	Scheduled O-Level Inspection Rate / 1000 EFH	0.000	0.000			
	Scheduled Man-Hours per Inspection	0.0	0.0			
	Scheduled % Removed at O-Level	100%	100%			
	Scheduled Man-Hours to R&R at O&I-Level	67.7	67.7			
	Scheduled % at O&I-Level requiring Repair	72%	0%			
	Scheduled Repair Cost at O&I-Level	\$28,193	\$39,648			
	Scheduled % Returned to Depot	28%	100%			
	Scheduled Man-Hours at Depot	0.0	0.0			

Scheduled % at Depot requiring Repair	0%	30%
Depot Repair Cost	\$14,400	\$14,400
Scheduled % Scrapped at Depot	100%	70%
Depot Hardware Scrap Cost	\$28,193	\$39,648
Lifetime Scheduled Hardware Repair Cost	\$6,354,650	\$1,352,389
Lifetime Scheduled Hardware Scrap Cost	\$2,471,253	\$8,688,348
Lifetime Scheduled Depot Labor (MMH)	0	0
Lifetime Scheduled Field Labor (MMH)	15,259	0

Unscheduled

Unscheduled Event Rate / 1000 EFH	1.200	1.146
Unscheduled % Removed at O&I-Level	100%	100%
Unscheduled Manhours to R&R at O&I-Level	92.2	86.2
Unscheduled Engine Test Time	1.5	0.0
Unscheduled % at O&I-Level requiring Repair	0%	0%
Unscheduled Repair Cost at O&I-Level	\$2,931	\$239
Unscheduled % Returned to Depot	100%	100%
Unscheduled Manhours at Depot	0	0.0
Unscheduled at Depot Requiring Repair	0%	0%
Unscheduled Repair Cost at Depot	\$0	\$0
Unscheduled % Scrapped at Depot	60%	3%
Depot Hardware Scrap Cost	\$28,193	\$39,648
Lifetime Unscheduled Hardware Repair Cost	\$0	\$0
Lifetime Unscheduled Hardware Scrap Cost	\$9,104,084	\$611,350
Lifetime Unscheduled Depot Labor (MMH)	0	0
Lifetime Unscheduled Field Labor (MMH)	50,429	44,305

RTOC Data

Lifetime Hardware Avoided	\$	7,277,901
Miscellaneous Hardware Cost Avoidance	\$	-

Lifetime Depot Labor Avoided	\$ -
Total Lifetime Cost Avoidance	\$ 7,277,901
Hardware \$ / 1000 EFH	\$ 16,227.20
Labor \$ / 1000 EFH	\$ -

Non-RTOC Data

Lifetime Field Maintenance Avoided (MMH)	21,384
Lifetime Field Inspection Hours Avoided (MMH)	0
Total Maintenance Hours Avoided	21,384
MMH / 1000 EFH Avoided due to modification	47.68

Safety Data

Does Mod Get Problem Below Safety Threshold?	YES
Delta Class A Rate (Initial - Mitigated)	0.000
Delta Class A Rate (Mitigated - Proposed)	0.010

Retrofit Cost

Unit Kit Cost (includes depot installation labor)	\$ 39,801
Install Engines Retrofit Cost	\$ 2,587,065
Spare Engines Retrofit Cost	\$ 477,612
Total Retrofit Cost	\$ 3,064,677

Installation Schedule

	# Engines	Fleet %	Values
Year 1	24	37%	1
Year 2	24	37%	0.8
Year 3	17	26%	0.6
Year 4	0	0%	0.4
Year 5			0.2

Total

65

100%

Total weighted	
Annual Percentage	0.822

Table 9 GE 100 Ejector Nozzle (Block 30)

Engine Groundrules Data

# Aircraft (Installed Engines)	477
# Spare Engines/Modules	0
Engine Flight Hours / Month	17
Throttle Acceleration Cycles / Engine Flight Hours	3
Steady State Years	20
Total estimated remaining EFH for fleet	1,946,160
Hourly Depot Labor Rate	\$93
Baseline NRIFSD / 100,000 EFH	0.05
Baseline Class A / 100,000 EFH	0.05

Block Effectivity	30
-------------------	----

Safety Inputs

	Initial	Mitigated	Proposed	Delta 1	Delta 2
Non-Recoverable In-Flight Shut-Downs / 100K EFH	0.000	0.000	0.000		
Class A Events / 100K EFH	0.000	0.000	0.000	0.000	0.000

RTOC Data

Lifetime Hardware Avoided	\$ 119,507,552
Miscellaneous Hardware Cost Avoidance	\$ 12,448
Lifetime Depot Labor Avoided	\$ 5,096,320
Total Lifetime Cost Avoidance	\$ 124,616,320
Hardware \$ / 1000 EFH	\$ 61,413.24
Labor \$ / 1000 EFH	\$ 2,618.65

Non-RTOC Data

Lifetime Field Maintenance Avoided (MMH)	753,680
Lifetime Field Inspection Hours Avoided (MMH)	0
Total Maintenance Hours Avoided	753,680

MMH / 1000 EFH Avoided due to modification

387.27

Safety Data

Does Mod Get Problem Below Safety Threshold?	YES
Delta Class A Rate (Initial - Mitigated)	0.000
Delta Class A Rate (Mitigated - Proposed)	0.000

Retrofit Cost

Unit Kit Cost (includes depot installation labor)	\$ 130,000
Install Engines Retrofit Cost	\$ 62,010,000
Spare Engines Retrofit Cost	\$ -
Total Retrofit Cost	\$ 62,010,000

*** Note: The contractor is also claiming \$130M lifetime savings for hardware returned to the spares pool that the AF will not have to buy if they incorporate this modification**

Installation Schedule	# Engines	Fleet %	Values
Year 1	144	30%	1
Year 2	144	30%	0.8
Year 3	144	30%	0.6
Year 4	45	9%	0.4
Year 5	0	0%	0.2
Total	477	100%	

Total weighted Annual Percentage	0.762
----------------------------------	-------

Table 10 GE 100 Ejector Nozzle (Block 40)

Engine Groundrules Data						
# Aircraft (Installed Engines)		321				
# Spare Engines/Modules		0				
Engine Flight Hours / Month		17				
Throttle Acceleration Cycles / Engine Flight Hours		3				
Steady State Years		20				
Total estimated remaining EFH for fleet		1,309,680				
Hourly Depot Labor Rate		\$93				
Baseline NRIFSD / 100,000 EFH		0.05				
Baseline Class A / 100,000 EFH		0.05				
Block Effectivity				40		
Safety Inputs						
Non-Recoverable In-Flight Shut-Downs / 100K EFH	Initial	0.000	Mitigated	0.000	Proposed	0.000
Class A Events / 100K EFH	Initial	0.000	Mitigated	0.000	Proposed	0.000
RTOC Data						
Lifetime Hardware Avoided	\$	119,507,552				
Miscellaneous Hardware Cost Avoidance	\$	12,448				
Lifetime Depot Labor Avoided	\$	5,096,320				
Total Lifetime Cost Avoidance	\$	124,616,320				
Hardware \$ / 1000 EFH	\$	91,258.93				
Labor \$ / 1000 EFH	\$	3,891.27				
Non-RTOC Data						
Lifetime Field Maintenance Avoided (MMH)		753,680				
Lifetime Field Inspection Hours Avoided (MMH)		0				
Total Maintenance Hours Avoided		753,680				

MMH / 1000 EFH Avoided due to modification

575.47

Safety Data

Does Mod Get Problem Below Safety Threshold? YES
 Delta Class A Rate (Initial - Mitigated) 0.000
 Delta Class A Rate (Mitigated - Proposed) 0.000

Retrofit Cost

Unit Kit Cost (includes depot installation labor) \$ 130,000
 Install Engines Retrofit Cost \$ 41,730,000
 Spare Engines Retrofit Cost \$ -
 Total Retrofit Cost \$ 41,730,000

*** Note: The contractor is also claiming \$130M lifetime savings for hardware returned to the spares pool that the AF will not have to buy if they incorporate this modification**

Installation Schedule	# Engines	Fleet %	Values
Year 1	96	30%	1
Year 2	96	30%	0.8
Year 3	96	30%	0.6
Year 4	33	10%	0.4
Year 5			0.2
Total	321	100%	

Total weighted Annual Percentage 0.759

Table 11 GE 129 Turbine Frame Outer Liner

Engine Groundrules Data

# Aircraft (Installed Engines)	249
# Spare Engines/Modules	54
Engine Flight Hours / Month	18
Throttle Acceleration Cycles / Engine Flight Hours	3
Steady State Years	25
Total estimated remaining EFH for fleet	1,344,600
Hourly Depot Labor Rate	\$93
Baseline NRIFSD / 100,000 EFH	0.05
Baseline Class A / 100,000 EFH	0.05

Block Effectivity	50
-------------------	----

	Initial	Mitigated	Proposed	Delta 1	Delta 2
Safety Inputs					
Non-Recoverable In-Flight Shut-Downs / 100K EFH	0.319	0.319	0.000		
Class A Events / 100K EFH	0.252	0.252	0.000	0.202	0.202
Scheduled					
Scheduled Maintenance Interval (TACs)	3000	999999999			
Scheduled Maintenance Rate / 1000 EFH	0.900	0.000			
Scheduled O-Level Inspection Rate / 1000 EFH	0.000	0.000			
Scheduled Man-Hours per Inspection	0.0	0.0			
Scheduled % Removed at O-Level	0%	0%			
Scheduled Man-Hours to R&R at O&I-Level	0.0	0.0			
Scheduled % at O&I-Level requiring Repair	0%	0%			
Scheduled Repair Cost at O&I-Level	\$0	\$0			
Scheduled % Returned to Depot	0%	0%			
Scheduled Man-Hours at Depot	0.0	0.0			
Scheduled % at Depot requiring Repair	0%	0%			

Depot Repair Cost	\$0	\$0
Scheduled % Scrapped at Depot	0%	0%
Depot Hardware Scrap Cost	\$0	\$0
Lifetime Scheduled Hardware Repair Cost	\$0	\$0
Lifetime Scheduled Hardware Scrap Cost	\$0	\$0
Lifetime Scheduled Depot Labor (MMH)	0	0
Lifetime Scheduled Field Labor (MMH)	0	0

<u>Unscheduled</u>		
Unscheduled Event Rate / 1000 EFH	0.064	0.000
Unscheduled % Removed at O&I-Level	100%	100%
Unscheduled Manhours to R&R at O&I-Level	68.3	68.3
Unscheduled Engine Test Time	3.0	3.0
Unscheduled % at O&I-Level requiring Repair	0%	0%
Unscheduled Repair Cost at O&I-Level	\$0	\$0
Unscheduled % Returned to Depot	100%	100%
Unscheduled Manhours at Depot	4.8	4.8
Unscheduled at Depot Requiring Repair	0%	0%
Unscheduled Repair Cost at Depot	\$0	\$0
Unscheduled % Scrapped at Depot	10%	10%
Depot Hardware Scrap Cost	\$189	\$189
Lifetime Unscheduled Hardware Repair Cost	\$0	\$0
Lifetime Unscheduled Hardware Scrap Cost	\$1,626	\$0
Lifetime Unscheduled Depot Labor (MMH)	413	0
Lifetime Unscheduled Field Labor (MMH)	6,136	0

RTOC Data		
Lifetime Hardware Avoided	\$	1,626
Miscellaneous Hardware Cost Avoidance	\$	-
Lifetime Depot Labor Avoided	\$	<u>38,415</u>

Total Lifetime Cost Avoidance	\$	40,041
Hardware \$ / 1000 EFH	\$	1.21
Labor \$ / 1000 EFH	\$	28.57

Non-RTOC Data

Lifetime Field Maintenance Avoided (MMH)	6,136
Lifetime Field Inspection Hours Avoided (MMH)	0
Total Maintenance Hours Avoided	6,136
MMH / 1000 EFH Avoided due to modification	4.56

Safety Data

Does Mod Get Problem Below Safety Threshold?	YES
Delta Class A Rate (Initial - Mitigated)	0.000
Delta Class A Rate (Mitigated - Proposed)	0.252

Retrofit Cost

Unit Kit Cost (includes depot installation labor)	\$	257
Install Engines Retrofit Cost	\$	63,993
Spare Engines Retrofit Cost	\$	13,878
Total Retrofit Cost	\$	77,871

Installation Schedule

	# Engines	Fleet %	Values
Year 1	90	36%	1
Year 2	90	36%	0.8
Year 3	69	28%	0.6
Year 4	0	0%	0.4
Year 5	0	0%	0.2
Total	249	100%	

Total weighted Annual Percentage	0.817
-------------------------------------	-------

Table 12 GE 129 Laser Shock Peen

Engine Groundrules Data

# Aircraft (Installed Engines)	249
# Spare Engines/Modules	54
Engine Flight Hours / Month	18
Throttle Acceleration Cycles / Engine Flight Hours	3
Steady State Years	25
Total estimated remaining EFH for fleet	1,344,600
Hourly Depot Labor Rate	\$93
Baseline NRIFSD / 100,000 EFH	0.05
Baseline Class A / 100,000 EFH	0.05

Block Effectivity	50
-------------------	----

	Initial	Mitigated	Proposed	Delta 1	Delta 2
Safety Inputs					
Non-Recoverable In-Flight Shut-Downs / 100K EFH	0.700	0.700	0.000		
Class A Events / 100K EFH	0.553	0.553	0.000	0.503	0.503

ECP Data

Scheduled

	Current	Proposed
Scheduled Maintenance Interval (TACs)	4000	4000
Scheduled Maintenance Rate / 1000 EFH	0.675	0.675
Scheduled O-Level Inspection Rate / 1000 EFH	0.000	0.000
Scheduled Man-Hours per Inspection	0.0	0.0
Scheduled % Removed at O-Level	100%	100%
Scheduled Man-Hours to R&R at O&I-Level	0.0	0.0
Scheduled % at O&I-Level requiring Repair	0%	0%
Scheduled Repair Cost at O&I-Level	\$0	\$0
Scheduled % Returned to Depot	100%	100%
Scheduled Man-Hours at Depot	0.0	0.0

Scheduled % at Depot requiring Repair	0%	0%	0%
Depot Repair Cost	\$0	\$0	\$0
Scheduled % Scrapped at Depot	10%	10%	10%
Depot Hardware Scrap Cost	\$28,661	\$28,661	\$49,423
Lifetime Scheduled Hardware Repair Cost	\$0	\$0	\$0
Lifetime Scheduled Hardware Scrap Cost	\$2,601,287	\$2,601,287	\$4,485,656
Lifetime Scheduled Depot Labor (MMH)	0	0	0
Lifetime Scheduled Field Labor (MMH)	0	0	0
<u>Unscheduled</u>			
Unscheduled Event Rate / 1000 EFH	151.442	151.442	19.353
Unscheduled % Removed at O&I-Level	1%	1%	1%
Unscheduled Manhours to R&R at O&I-Level	22.8	22.8	22.8
Unscheduled Engine Test Time	0.0	0.0	0.0
Unscheduled % at O&I-Level requiring Repair	0%	0%	0%
Unscheduled Repair Cost at O&I-Level	\$0	\$0	\$0
Unscheduled % Returned to Depot	100%	100%	100%
Unscheduled Manhours at Depot	4.8	4.8	4.8
Unscheduled at Depot Requiring Repair	0%	0%	0%
Unscheduled Repair Cost at Depot	\$0	\$0	\$0
Unscheduled % Scrapped at Depot	1%	1%	1%
Depot Hardware Scrap Cost	\$3,583	\$3,583	\$6,178
Lifetime Unscheduled Hardware Repair Cost	\$0	\$0	\$0
Lifetime Unscheduled Hardware Scrap Cost	\$72,960	\$72,960	\$16,076
Lifetime Unscheduled Depot Labor (MMH)	9,774	9,774	1,249
Lifetime Unscheduled Field Labor (MMH)	46,427	46,427	5,933

RTOC Data

Lifetime Hardware Avoided	\$	(1,827,486)
Miscellaneous Hardware Cost Avoidance	\$	-

Lifetime Depot Labor Avoided	\$ 792,837
Total Lifetime Cost Avoidance	\$ (1,034,649)
Hardware \$ / 1000 EFH	\$ (1,359.13)
Labor \$ / 1000 EFH	\$ 589.65

Non-RTOC Data

Lifetime Field Maintenance Avoided (MMH)	40,494
Lifetime Field Inspection Hours Avoided (MMH)	0
Total Maintenance Hours Avoided	40,494
MMH / 1000 EFH Avoided due to modification	30.12

Safety Data

Does Mod Get Problem Below Safety Threshold?	YES
Delta Class A Rate (Initial - Mitigated)	0.000
Delta Class A Rate (Mitigated - Proposed)	0.553

Retrofit Cost

Unit Kit Cost (includes depot installation labor)	\$ 14,225
Install Engines Retrofit Cost	\$ 3,542,025
Spare Engines Retrofit Cost	\$ 768,150
Total Retrofit Cost	\$ 4,310,175

Installation Schedule

	# Engines	Fleet %	Values
Year 1	28	11%	1
Year 2	35	14%	0.8
Year 3	72	29%	0.6
Year 4	53	21%	0.4
Year 5	0	0%	0.2

Total

188

76%

Total weighted Annual Percentage	0.484
-------------------------------------	-------

APPENDIX E: Macros created for value functions

The Visual Basic for Application functions, shown below, converts the alternatives' score to values using single dimensional value functions based on the preferences of the decision-maker under each objective.

```
Function UER(score)
If score >= 0 And score <= 0.0714 Then+
Select Case score
Case Is >= 0 And score <= 0.0714
    UER = (score - 0) / (0.0714 - 0)
End Select
Else
    MsgBox "The score is not within the range of evalaution measure"
End If
End Function
```

```
Function Delta1(score)
If score >= 0 And score <= 0.7 Then
    Select Case score
    Case Is <= 0.091
        Delta1 = (score - 0) / ((0.091 - 0) * 10)
    Case Is <= 0.7
        Delta1 = (1 - Exp(-(score - 0.091) / 0.5)) / (1 - Exp(-(0.7 - 0.091) / 0.5))
    End Select
Else
    MsgBox "The score is not within the range of evalaution measure"
End If
End Function
```

```
Function Delta2(score)
If score >= 0 And score <= 0.7 Then
    Select Case score
    Case Is <= 0.091
        Delta2 = (score - 0) / ((0.091 - 0) * 10)
    Case Is <= 0.7
        Delta2 = (1 - Exp(-(score - 0.091) / 0.2)) / (1 - Exp(-(0.7 - 0.091) / 0.2))
    End Select
Else
```

```

    MsgBox "The score is not within the range of evalaution measure"
End If
End Function

```

```

Function Install(score)
If score >= 0.4 And score <= 1 Then
    Install = (score - 0.4) / (1 - 0.4)
Else
    MsgBox "The score is not within the range of evalaution measure"
End If
End Function

```

```

Function Partscost(score)
score = score + 1359
If score >= 0 And score <= 100000 Then
score = score / 100000
Partscost = (1 - Exp(-(score - 0) / -0.5)) / (1 - Exp(-(1 - 0) / -0.5))
Else
    MsgBox "The score is not within the range of evalaution measure"
End If
End Function

```

```

Function Laborcosts(score)
If score >= 0 And score <= 5000 Then
score = score / 5000
Laborcosts = (1 - Exp(-(score - 0) / -1)) / (1 - Exp(-(1 - 0) / -1))
Else
    MsgBox "The score is not within the range of evalaution measure"
End If
End Function

```

```

Function MMH(score)
If score >= 0 And score <= 600 Then
    score = score / 600
    MMH = (1 - Exp(-(score - 0) / -1)) / (1 - Exp(-(1 - 0) / -1))
Else
    MsgBox "The score is not within the range of evalaution measure"
End If

End Function

```

Function DWV below, incorporates the decision weights into the sub-model. In a spreadsheet, it compares the aircraft types (Bltype1 and Bltype2) and if they are same, it multiplies the value with the decision weight for that specific block to find the value of a modification for a specific block type.

```
Function DWV(Bltype1, value, Bltype2, weight)
If Bltype1 = Bltype2 Then
DWV = value * weight
Else
DDWV = 0
End If
End Function
```

Bibliography

- Aaker, David A. and Tyzoon T. Tyebjee. "A Model for the Selection of Interdependent R&D Projects." IEEE Transactions on Engineering Management EM-25, No. 2 (May 1978) 30-36.
- Air Force Instruction 91-204 available at
<http://afpubs.hq.af.mil/pubfiles/af/91/afi91-204/afi91-204.pdf>
- Baker, N. and J. Freeland. "Recent Advantages in R&D Benefit Measurements and Project Selection Methods." Management Science, No. 21 (June 1975) 1164-1174.
- Bard, Jonathan F. "A Comparison of the Analytic Hierarchy Process with Multiattribute Utility Theory: A Case Study." IIE Transactions 24, No. 5 (November 1992) 111-121.
- Bell, F. V. and Read, A. W. "The Application of a Research Project Selection Method." R&D Management 1, No. 1 (1970).
- Belton, Valerie. "A Comparison of the Analytic Hierarchy Process and a Simple Multiattribute Value Function." European Journal of Operational Research 26 (1986) 7-21.
- Biondi, Leonardo and Ricordo, Galli. "Technological Trajectories." Futures 24, No. 6 (July 1992) 580-592.
- Bullerman, Brian. (Capt.) "F-16 Engine." Personal Interview, 2000.
- Bunn, Derek. "Applied Decision Analysis." New York: McGraw-Hill, 1984.
- Burk, Roger C. and Parnell Gregory S. "Evaluating Future Military Space Technologies." Interfaces, No. 27 (1997) 60-73.
- Bretschneider, Stuart. "Operations Research Contributions to Evaluation of R&D Projects." In Evaluating R&D Impacts: Methods and Practice. Boston: Academic Publishers, 1993.
- Clemen, Robert T. "Making Hard Decisions: An Introduction to Decision Analysis." Duxbury Press: Pacific Grove, 1996.
- Costing and Charging for Research, available at
<http://www.acs.uwa.edu.au/research/policy/gp/avcc/costing.html>
- Deckro, Richard. "Synergistic Decision-Making Brief." 2000.
- Desac Strategic Plan available at
<http://www.safaqxt.rtoc.hq.af.mil/documents/webbrief.ppt>.

F-16 Combat Legacy, F-16 Information available at
<http://www.f-16.net/library/legacy.html>.

F-16 RTOC Briefing available at
<http://www.safaqxt.rtoc.hq.af.mil/documents/F-16Jackson.ppt>.

F-16 Safety, Lockheed Martin Tactical Aircraft Systems available at
http://www.lmtas.com/FighterPrograms/F16/feat_details/safety.html.

F-16 System Safety Program Plan for Acquisition Reform. 16PP2960. 30 September 1998.

Fighter Programs available at
http://www.lmaeronautics.com/tfetext_only/fighter_programs/f16/f16_features.html.

GE Military Engines available at
<http://www.geae.com/military>

Gear, A.E., A.G. Lockett, and A.W. Pearson. "Analysis of Some Portfolio Selection Models for R&D." IEEE Transactions on Engineering Management EM-18, No. 2 (May 1971) 66-76.

Golabi, K. C. Kirkwood and C. Sicherman. "Selecting a Portfolio of Solar Energy Projects Using Multiattribute Preference Theory." Management Sciences 27, No. 2 (February 1981), 174-189.

Hammond, John S., Keeney Ralph L., and, Raiffa H. "Smart Choices." Boston, MA: Harvard Business School Press, 1999.

Keeney, Ralph L. and Howard Raiffa. "Decisions with Multiple Objectives: Preferences and Value Tradeoffs." New York: John Wiley & Sons, 1976.

Keeney, Ralph L. "Value Focused Thinking: A Path to Creative Decision Making." Cambridge, Mass: Harvard University Press, 1992.

Kirkwood, Craig W. "Strategic Decision Making: Multiobjective Decision Analysis with Spreadsheets." Belmont, CA: Wadsworth Publishing, 1997.

Kloeber, Jack M. "VFT Slides." 1999

Kloeber, Jack M. "An Analysis of the Analytical Hierarchy Process." Revised Edition, July 2000.

- Kloeber, Jack M. Ralston, Brian E. and Deckro, Richard F. "Selecting a Portfolio of Technologies: An Application of Decision Analysis." *Decision Sciences* 30, No. 1 (Winter 1999) 217-236.
- Kricker, James. (Maj.) "F-16 Safety." Personal Interview, 2000.
- Logical Decisions for Windows 95, Version 5.0 Computer Software. Logical Decisions, 1998.
- Microsoft Excel 97 for Windows. Computer Software, 1996.
- Nutt, A.B. "An approach to Research and Development Effectiveness." *IEEE Transactions on Engineering Management* EM-12, No. 3 (September 1965) 103-112.
- Nutt, Paul C. "Making Tough Decisions." San Francisco, CA: Jossey-Bass Inc., 1989.
- Parnell, Gregory S., Maj. Harry W. Conley, Col. Jackson A. Jackson, Lt. Col. Lee J. Lehmkuhl and Col. John M. Andrew. "Foundations 2025: A Value Model for Evaluating Future Air and Space Forces." *Management Sciences* 44 No. 10 (October 1998) 1336-1350.
- Ragsdale, Cliff T. "Spreadsheet Modeling and Decision Analysis." Cincinnati: South Western Publishing, 2001.
- Roberts, Fred S. "Measurement Theory with Applications to Decision Making, Utility, and the Social Sciences." Reading, Massachusetts: Addison-Wesley Publish Company, 1979.
- Pratt Whitney Military Engines available at <http://www.pratt-whitney.com>
- RTOC Best Practices and Lessons Learned available at <http://www.acq.osd.mil/cgi-bin> .
- Saaty, T. "The Analytical Hierarchy Process." New York: McGraw- Hill International, 1980.
- Schmidt, Robert L. "A Model for R&D Project Selection with Combined Benefit, Outcome, and Resource Interactions." *IEEE Transactions on Engineering Management* 40, No. 4 (November 1993) 403-410.
- Smart Munitions, The Next Generations available at <http://vectorsite.tripod.com/avbomb8.html>.
- Sperling, Brian K. "A value Focused Approach to Determining the Top Ten Hazards in Army Aviation." Thesis, Master of Sciences, Air Force Institute of Technology, AFIT/GOR/ENS/99M, 1999.
- The Nation's Air Force, Combat Capability available at <http://www.af.mil/lib/nations/index.html>.

Von Winterfeldt, Detlof and Ward, Edwards. "Decision Analysis and Behavioral Research."
Cambridge: Cambridge University Press, 1986.

Weintgartner, H. M. "Mathematical Programming and Analysis of Capitol Budgeting
Problems." Edgewood Cliffs, NJ: Prentice Hall, 1963.

Winston, Wayne L. "Operations Research Applications and Algorithms." Belmont, CA:
Duxbury Press, 1994.

REPORT DOCUMENTATION PAGE

Form Approved
OMB No. 074-0188

The public reporting burden for this collection of information is estimated to average 1 hour per response, including the time for reviewing instructions, searching existing data sources, gathering and maintaining the data needed, and completing and reviewing the collection of information. Send comments regarding this burden estimate or any other aspect of the collection of information, including suggestions for reducing this burden to Department of Defense, Washington Headquarters Services, Directorate for Information Operations and Reports (0704-0188), 1215 Jefferson Davis Highway, Suite 1204, Arlington, VA 22202-4302. Respondents should be aware that notwithstanding any other provision of law, no person shall be subject to a penalty for failing to comply with a collection of information if it does not display a currently valid OMB control number.

PLEASE DO NOT RETURN YOUR FORM TO THE ABOVE ADDRESS.

1. REPORT DATE 02-23-01		2. REPORT TYPE Master's Thesis		3. DATES COVERED (From - To) Aug 2000 - Mar 2001						
4. TITLE AND SUBTITLE TECHNOLOGY SELECTION FOR ENHANCING F-16 CAPABILITY: AN ANALYSIS USING VALUE FOCUSED THINKING			5a. CONTRACT NUMBER 5b. GRANT NUMBER 5c. PROGRAM ELEMENT NUMBER 5d. PROJECT NUMBER 5e. TASK NUMBER 5f. WORK UNIT NUMBER							
6. AUTHOR Yay, Cihangir, 1 st Lieutenant, TUAF			8. PERFORMING ORGANIZATION REPORT NUMBER AFIT/GOR/ENS/01M-19							
7. PERFORMING ORGANIZATION NAME AND ADDRESS Air Force Institute of Technology Graduate School of Engineering and Management (AFIT/EN) 2950 P Street, Building 640 WPAFB OH 45433-7765			9. SPONSORING/MONITORING AGENCY NAME AND ADDRESS Attn: Maj. Jim Kricker F-22 ACCSO-A COM 937-255-1711 ext 2411 DSN 785-1711 ext 2411 Email: James.Kricker@wpafb.af.mil							
10. SPONSOR/MONITOR'S ACRONYM			11. SPONSOR/MONITOR'S REPORT NUMBER							
12. DISTRIBUTION/AVAILABILITY STATEMENT APPROVED FOR PUBLIC RELEASE; DISTRIBUTION UNLIMITED.										
13. SUPPLEMENTARY NOTES										
14. ABSTRACT This study, with support of the Aeronautical Systems center, builds a scientific decision support system intended for Air Combat Command. Past decision-making techniques are discussed and their limitations are explained. Two multiattribute decision-making techniques, analytical hierarch process and value focused thinking, are studied. Due to limitations of analytical hierarchy process, value focused thinking is accepted as the best fit for our problem. A value hierarchy model is developed using value focused thinking for selecting the most beneficiary F-16 engine modifications depending on Air Combat Command values. Ten modifications are ranked using value model to validate the process. Cost is involved in the rankings to show the benefit per dollar invested. Optimization techniques are used to form various effective modification sets due to changing budget constraints. Sensitivity analyses show that the model is weight sensitive. This study proves that multiattribute decision-making techniques and particularly value focused thinking approach can be used to create a scientific decision support system for Air Combat Command.										
15. SUBJECT TERMS Decision Analysis, Value Focused Thinking, F-16 Capability Enhancement Model, Portfolio Analysis, Integer Programming Optimization										
16. SECURITY CLASSIFICATION OF:		17. LIMITATION OF ABSTRACT	18. NUMBER OF PAGES	19a. NAME OF RESPONSIBLE PERSON Chambal, Stephen P., Capt.						
<table border="1" style="width: 100%; border-collapse: collapse;"> <tr> <td style="width: 33%; text-align: center;">a. REPORT</td> <td style="width: 33%; text-align: center;">b. ABSTRACT</td> <td style="width: 33%; text-align: center;">c. THIS PAGE</td> </tr> <tr> <td style="text-align: center;">U</td> <td style="text-align: center;">U</td> <td style="text-align: center;">U</td> </tr> </table>	a. REPORT	b. ABSTRACT	c. THIS PAGE	U	U	U	UU	186	19b. TELEPHONE NUMBER 255-6565 Ext. 4314 Email: Stephen.Chambal@afit.edu	
a. REPORT	b. ABSTRACT	c. THIS PAGE								
U	U	U								